

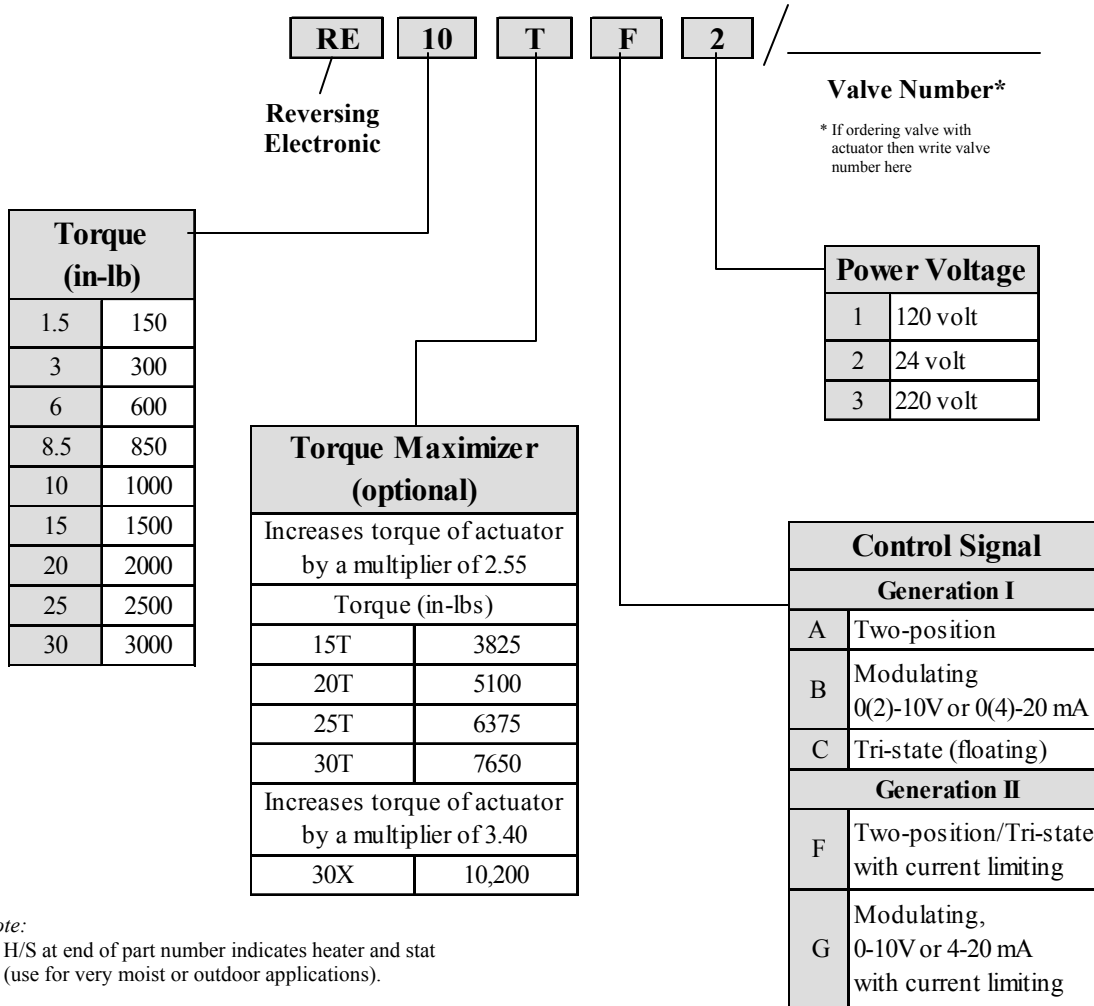

## How to Select the RE Industrial Actuator Part Number



*Note:*

- H/S at end of part number indicates heater and stat (use for very moist or outdoor applications).

Example: Torque Part No.  
 1000 in-lb ..... RE10  
 5100 in-lb ..... RE20T





## RE Series Industrial Actuators Features and Benefits

Features	Benefits
Solid state industrial 1/4 turn actuators with current limiting	Actuator stops and holds position when current setpoint is exceeded. Can continue to operate if driven in the opposite direction.
Field adjustable speed setting standard	Can slow speed of actuator by a factor of 2 (i.e. 90 degrees of rotation can be slowed from 35 seconds to 70 seconds).
Optically isolated signal inputs	Power and signal do not have to come from the same source (no more ground loop problems).
Inputs are not polarity sensitive for on/off or tri-state control	Positive and negative are interchangeable. Easier wiring, application and troubleshooting.
LED diagnostic indicators 2 end of travel and 2 torque related	Simple troubleshooting.
Standard 4 Amp knife blade standard automotive fuse	Commonly available.
True 100 % Duty Cycle	Requires no rest period between cycles.
Solid state braking system works with or without power (rated to 1-1/4 X torque)	Prevents valve or damper from drifting when power is absent. Not moisture sensitive. Elect./Mechanical brakes tend to be extremely sensitive to moisture and can lock up.
Heavy duty terminals for field interface	Fast, reliable field hook-up.
Designed with higher voltage electronic components	Reduces typical static and handling problems.
Automatic adjustment for damper or valve seal wear	Current limiting feature ensures positive close-off. Prevents jamming the damper or driving the valve too far into seat.
Two-position control: Wide input signal voltage range (9 - 130 VAC or VDC)	Allows for long distance signal runs. Flexibility also allows for early commissioning.
Entire Actuator is UL508 and cUL C22.2 No. 14-M91 listed.	Meets rigid engineering specifications



**RE Series Industrial NEMA 4/4X Type Actuators  
Torque: 150 In-Lb to 10,200 In-Lb**

<b>Technical Data</b>	<b>RE1.5F - RE8.5F</b>	<b>RE1.5G - RE8.5G</b>	<b>RE10F-RE30XF</b>	<b>RE10G - RE30XG</b>
Power supply	12 VDC, 24 VAC or VDC, 120 VAC, 50/60 Hz, other options available			
Power Consumption	30 VA (Class 2 power source required)		56 VA (Class 2 power source required)	
Electrical connection	Dual conduit entry (1/2")		Dual conduit entry (3/4")	
Overload protection	Electronic - Solid State			
Control signal	Two-pos./tri-state* (floating)	0-10 VDC, 4-20 mA std., field adj.	Two-pos./tri-state* (floating)	0 -10 VDC, 4-20 mA std., field adj.
Input impedance	250 Ohms for 4 - 20 mA			
Operating range	0 to 10 VDC, 2 to 10 VDC, 4 to 20 mA, custom signal ranges available			
Feedback output	0 to 10 VDC standard, 4 to 20 mA optional			
Angle of rotation	Typically 90°, Option: adjustable 65° to 320°			
Minimum torque	Depends on model - see Table			
Direction of rotation	Standard: increase signal = CCW (jumper selectable)			
Position indication	Visual mechanical position indicator			
Gear train	Heat treated metal gears, permanently lubricated			
Brakes	Solid State braking system (power not required)			
Manual override	De-clutching shaft with flats, optional override handwheel			
Duty cycle	100%			
Auxiliary switches - Switch - Range usage - Factory setting - Ratings (Resistive)	1 standard, up to 3 optional Form C; SPDT 0 - 320° None - 125/250 VAC: 10 Amps, 1/3 hp - 12 VDC: 5.0 Amps; 30 VDC: 2.0 Amps Customs Available - Call Dodge Engineering			
Switch connections:	Male quick connect type tabs			
Control signal adjustment: (for modulating units) - Offset (startpoint) - Factory setting - Span	-	0 - 3 VDC 0 - 10 VDC or 4-20 mA Adjustable	-	0 - 3 VDC 0 - 10 VDC or 4-20 mA Adjustable
Running time (90°)(nominal)	Adjustable - See RE Series Industrial Actuators Table			
Humidity	95% RH, noncondensing			
Operating temperature†	-40°F to 150°F (-40°C to 65°C)			
Agency Compliance	UL 508 Listed, File E253925; cUL Certified to Canadian standard C22.2 No. 14-M91***			
Housing type	Type 4/4X according to UL, cUL			
Housing material	Cast aluminum, with exterior grade polyurethane enamel coating.			
Options: - Heater & thermostat † - Override handwheel - Alarm relay	For outdoor and moist environments Non-spoked for safety Output - rating 130 mA max., 9 - 130 VAC/DC			
Servicing	Maintenance free			
Weight	17 lbs		25 lbs ††	

**Notes:**

\* Input signal range from 9 - 130 VAC or VDC. Use normal switched signals only (i.e. relay contacts or switches).

**Do Not Use Triacs.**

\*\* Does not include line loss. Add 16 VA if heater and stat (H/S) is used.

\*\*\* Request certification at time of order.

† Optional heater and stat required for low temperatures, high humidity, extreme condensation or outdoor applications.

†† For "T" and "X" versions add 38 and 78 lbs respectively for the Torque Maximizer models.



RE Series Industrial Actuators					
Actuator Model No.	Output Torque		Speed* sec./90°	Speed** sec./270°	Speed** sec./360°
	in-lb	N-m			
RE1.5	150	17	10 - 25	—	—
RE3†	300	34	10 - 25	—	—
RE6	600	68	10 - 25	—	—
RE8.5	850	96	10 - 25	—	—
RE10†	1000	114	35 - 70	—	—
RE15	1500	170	35 - 70	—	—
RE20	2000	227	35 - 70	—	—
RE25	2500	284	35 - 70	—	—
RE30	3000	340	35 - 70	—	—
RE15T**	3825	434	—	105 - 210	—
RE20T**	5100	579	—	105 - 210	—
RE25T**	6375	724	—	105 - 210	—
RE30T**	7650	869	—	105 - 210	—
RE30X**	10200	1158	—	—	140-280

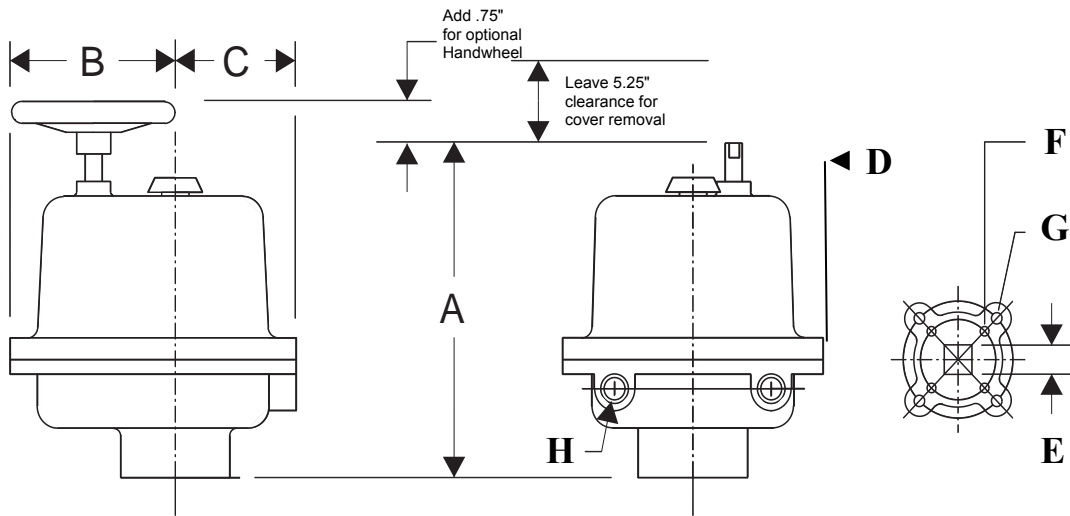

RE Series Industrial Actuators Dimensions								
Actuator Model No.	Dimensions (Inches)							
	A	B	C	D	E	F	G	H
RE1.5 - RE8.5	9.93	5.15	3.48	7.42	0.75 sq. 0.63 deep	N/A	5/16-18UNC-2B 0.625 deep BC: 3.25	1/2" NPT
RE10 - RE30	11.65	6.07	4.40	9.75	1.00 sq. 2.00 deep	3/8-16UNC-2B 1.12 deep BC: 4.00	7/16-14UNC-2B 1.50 deep BC: 4.965	3/4" NPT

*Notes:*

\* Speed is adjustable and varies slightly with load.

\*\* When using a Torque Maximizer, see page AC-11 in our DEI catalog for further details and requirements.

† Faster speeds available. Please call DEI.



### RE Current Limited Board Example Wiring For 2-wire On/Off control applications

Example uses same 24VAC for power and signal(see note 5)

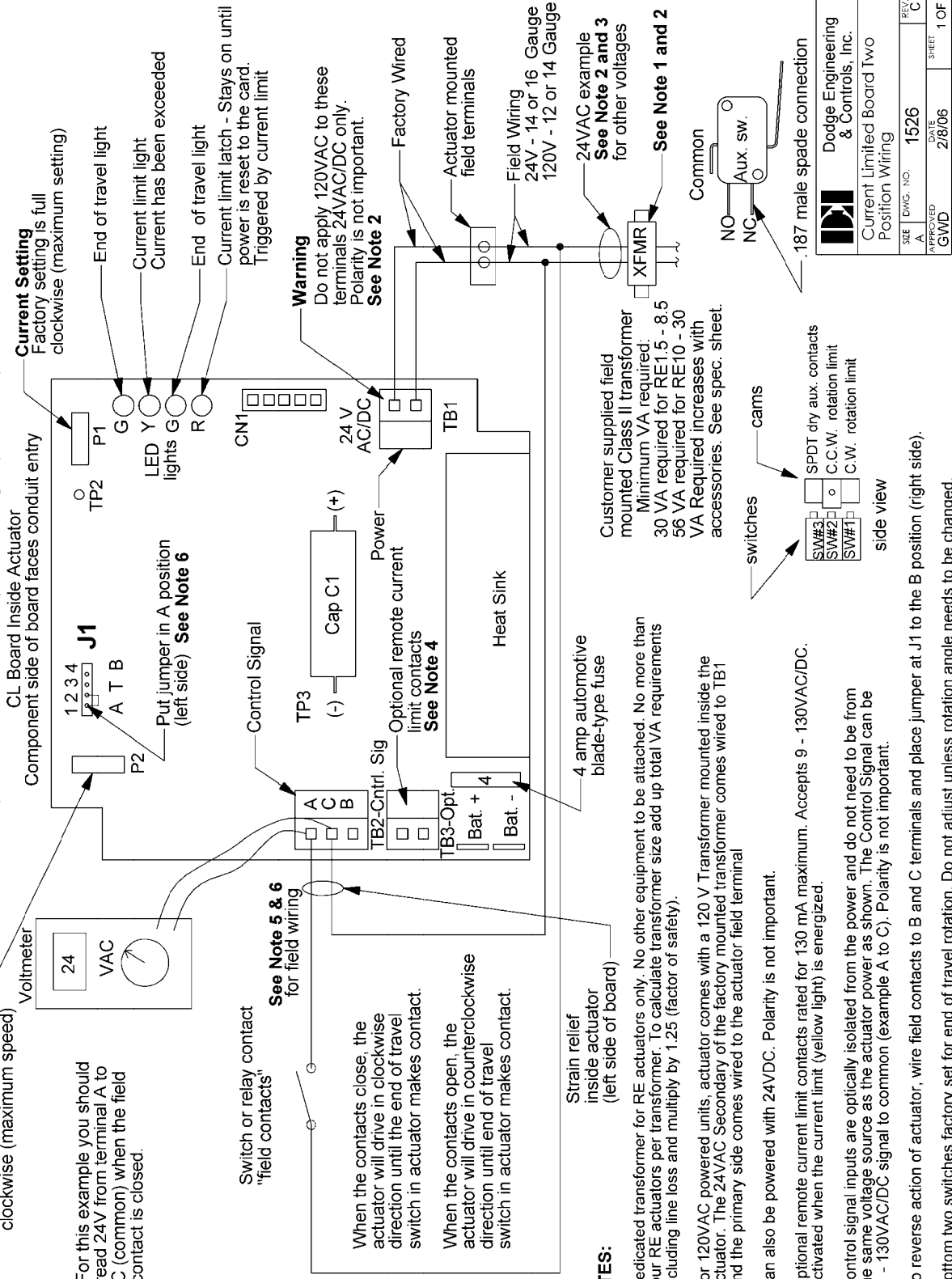

Dodge Engineering & Controls, Inc.	
Current Limited Board Two Position Wiring	
SHEET NO. A	REV. C
DWG. NO. 1526	DATE 2/8/06
APPROVED GWD	SHEET 1 OF 1





### RE Current Limited Board Example Wiring When Used With A Modulating Control Board

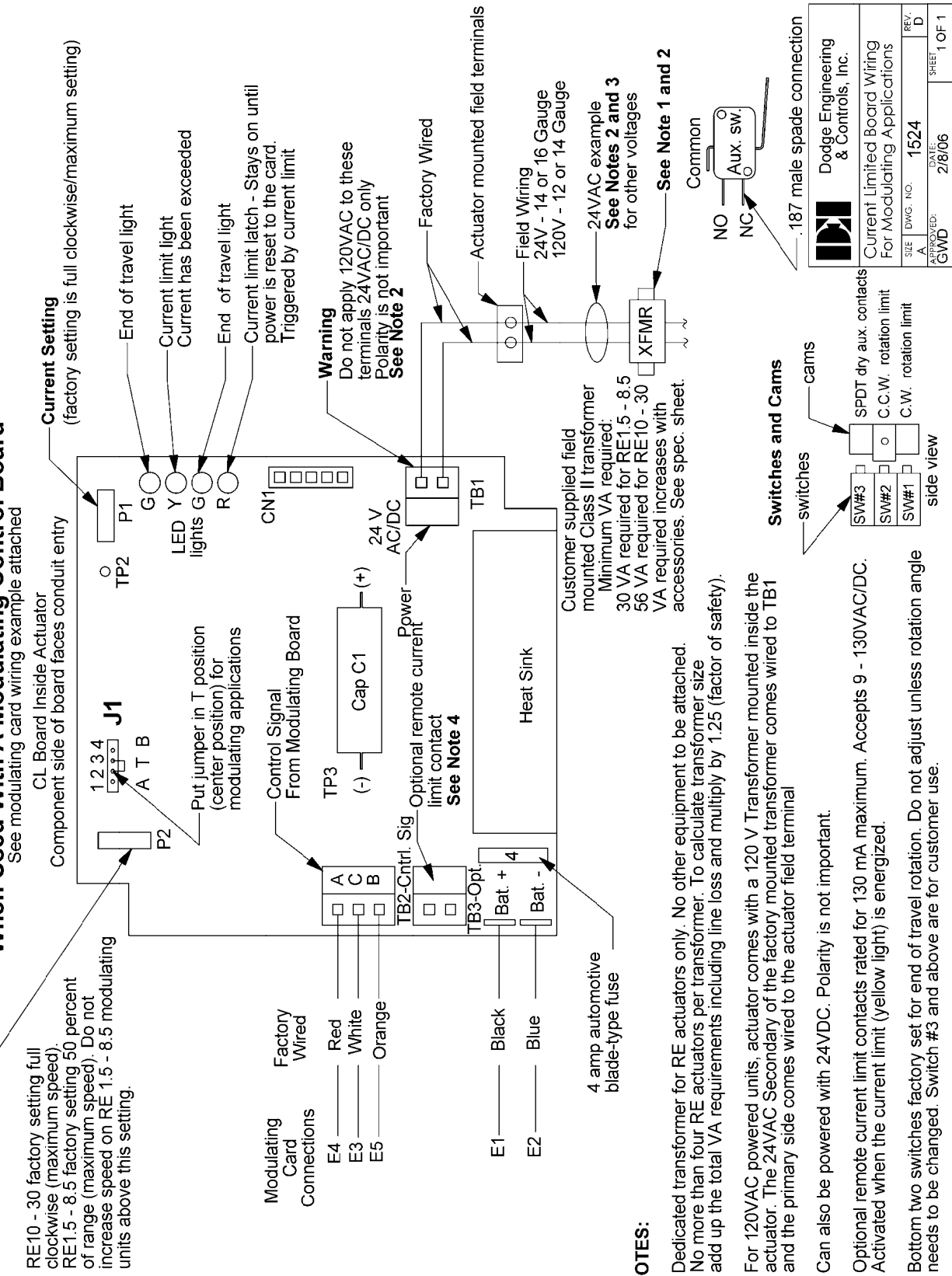

Dodge Engineering & Controls, Inc.	
Current Limited Board Wiring For Modulating Applications	
SIZE	DWG. NO. 1524
REV. D	DATE: 2/8/06
APPROVED: GWD	SHEET 1 OF 1

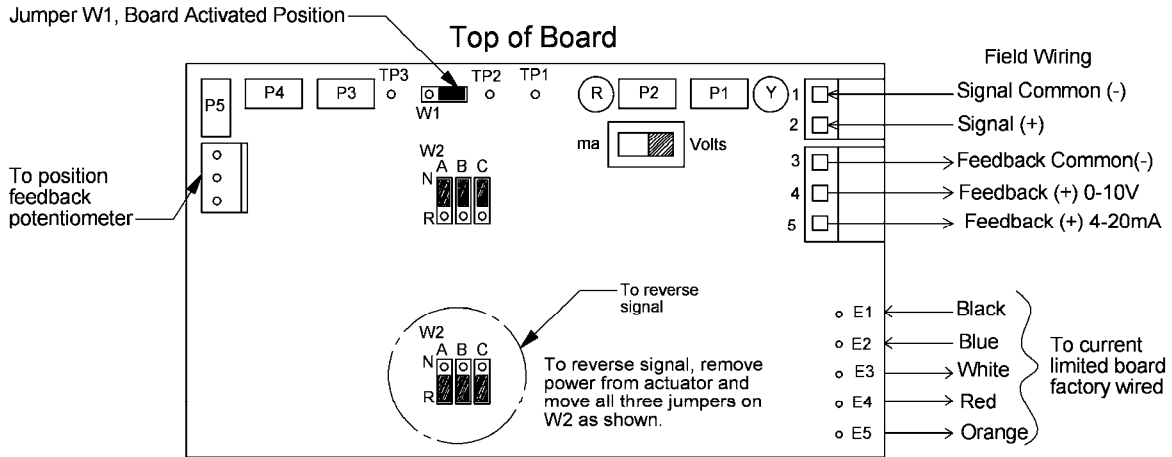
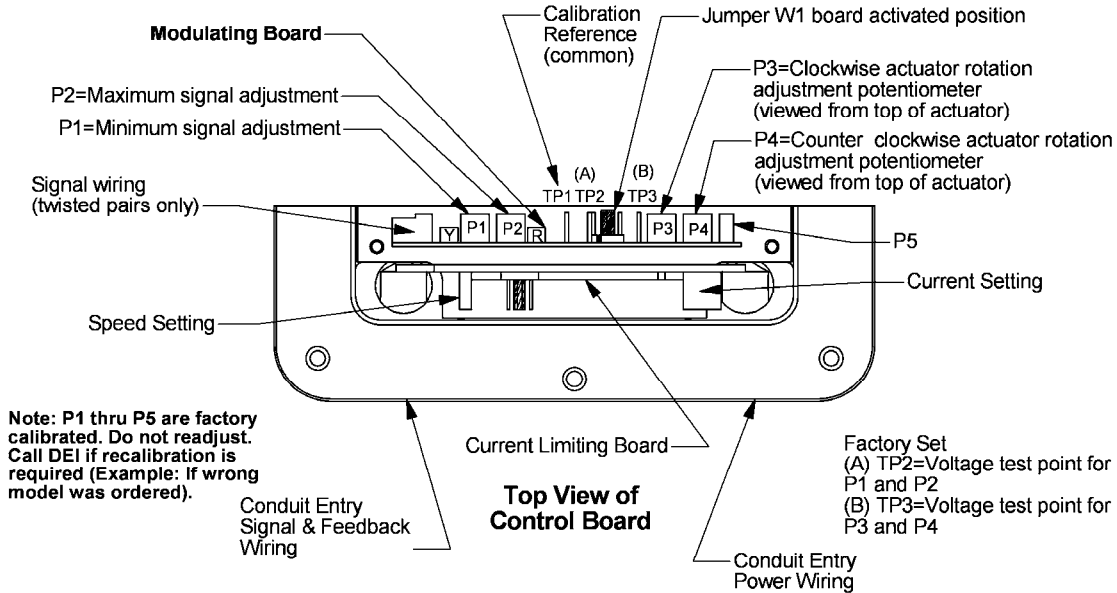

**Modulating Board Component Side**

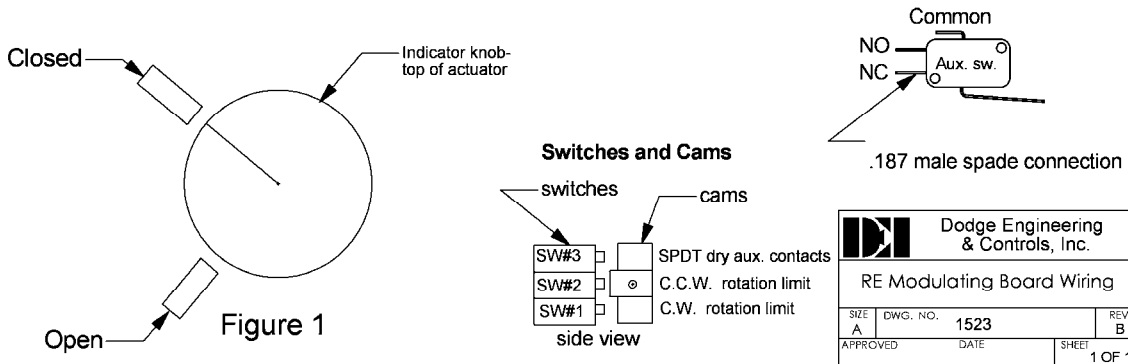



## Torque Maximizer

The Torque Maximizer permits DEI's actuators to operate at required torques up to 10,200 in-lbs. It also allows the actuator to be mounted in applications with space or location limitations.

**Operation:** The Torque Maximizer provides added gear reduction between the actuator and the valve or damper, thereby increasing the torque of the actuator. This product is 85% efficient in transferring the torque from the input to output drive shaft. This unit bolts directly onto the base of the DEI actuator, then the combined actuator/gear operator unit is mounted to the valve, damper or other application.

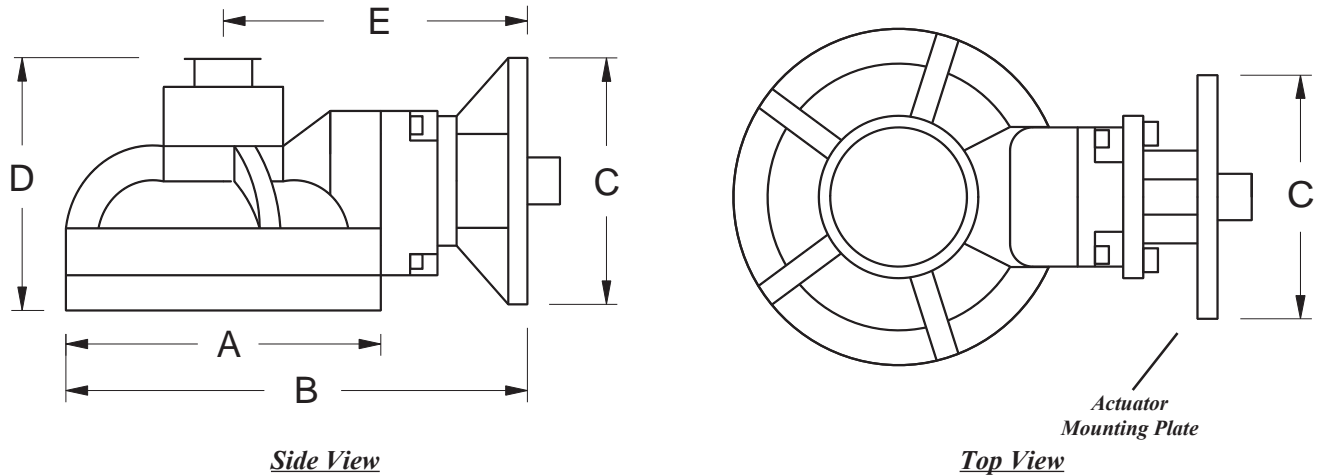

Model	Weight lbs (kg)	Dimensions in (mm)				
		A	B	C	D	E
T	38	7.25	10.63	5.25	4.63	7.00
	(17)	(184)	(270)	(133)	(118)	(178)
X	78	11.25	15.50	5.25	6.63	9.88
	(35)	(286)	(394)	(133)	(169)	(251)

**Rotation Time:** The Torque Maximizer gear unit model T (3:1 gear ratio) requires 270° of rotation to the input shaft to rotate the output shaft 90°. Model X (4:1 gear ratio) requires 360° of rotation for 90° of rotation at the output shaft. Therefore the time it takes to rotate the output shaft of the Model T 90° is 3 times the values listed on the "RE" product specification sheet for 90° rotation. The Model X requires 4 times the values listed for the respective actuator. Please note that many applications do not require the output shaft to turn a full 90°, thereby reducing the time.

Both models are furnished with a semi-gloss black, baked epoxy, powder coat paint finish.

Torque Maximizer Input/Output						
Model	Input Torque		Output Torque		Gear Ratio	Mech. Advantage
	in-lb	N-m	in-lb	N-m		
RE15T	1,500	169	3,825	432	3:1	2.55
RE20T	2,000	225	5,100	576	3:1	2.55
RE25T	2,500	282	6,375	720	3:1	2.55
RE30T	3,000	338	7,650	864	3:1	2.55
RE30X	3,000	338	10,200	1,152	4:1	3.40

**Notes:**

- Pictures not drawn to scale
- For overall assembly dimension to valve, call DEI.