

# ES177B2-ZS(-S) Series Proportional Electric Spring Return Actuators

## Installation Instructions

Part No. 34-636-1883, Rev. —  
Issued September 20, 2006

### Applications

The ES177B2-ZS(-S) Series Proportional Electric Actuators are direct-mount, spring return electric actuators that operate on AC/DC 24 V power. These bidirectional actuators do not require a damper linkage and are easily installed on dampers with 1/2 to 3/4 in. or 13 to 19 mm round shafts, or 3/8 and 1/2 in. or 10, 12, and 14 mm square shafts using the standard shaft clamp included with the actuator. An optional M9220-600 Jackshaft Coupler Kit is available for 3/4 to 1-1/16 in. or 19 to 27 mm round shafts, or 5/8 and 3/4 in. or 16, 18, and 19 mm square shafts.

A single ES177B2-ZS(-S) Series Proportional Electric Spring Return Actuator provides a running and spring return torque of 177 lb-in (20 N·m). Two or three like models mounted in tandem using the M9000-158 Tandem Mounting Kit deliver twice or triple the torque (354 lb-in [40 N·m] or 531 lb-in [60 N·m]). Integral line voltage auxiliary switches are available on the ES177B2-ZS-S models to indicate end-stop position or to perform switching functions within the selected rotation range.

**IMPORTANT:** Use this ES177B2-ZS(-S) Series Proportional Electric Spring Return Actuator only to control equipment under normal operating conditions. Where failure or malfunction of the electric actuator could lead to personal injury or property damage to the controlled equipment or other property, additional precautions must be designed into the control system. Incorporate and maintain other devices such as supervisory or alarm systems or safety or limit controls intended to warn of, or protect against, failure or malfunction of the electric actuator.

### Installation

The ES177B2-ZS(-S) Series Proportional Electric Spring Return Actuators mount directly to the surface in any convenient orientation using two M3 x 9.5 mm self-drilling sheet metal screws and the anti-rotation bracket (parts included with the actuator). No additional linkages or couplers are required. Electrical connections are color-coded and identified with numbers permanently marked on the actuator cable. A tag on the actuator cable identifies the electrical connections, and wiring details are also included on the actuator housing.

**IMPORTANT:** Do not install or use this ES177B2-ZS(-S) Series Proportional Electric Spring Return Actuator in or near environments where corrosive substances or vapors could be present. Exposure of the electric actuator to corrosive environments may damage the internal components of the device, and will void the warranty.

### Parts Included

- proportional electric spring return actuator with coupler
- anti-rotation bracket
- manual override crank
- two M3 x 9.5 mm self-drilling sheet metal mounting screws
- two No. 10-32 x 9/16 in. thread-forming conduit screws

### Special Tools Needed

- torque wrench with 3/8 in. (10 mm) socket
- digital voltmeter or M9000-200 Commissioning Tool
- flat blade screwdriver

## Dimensions

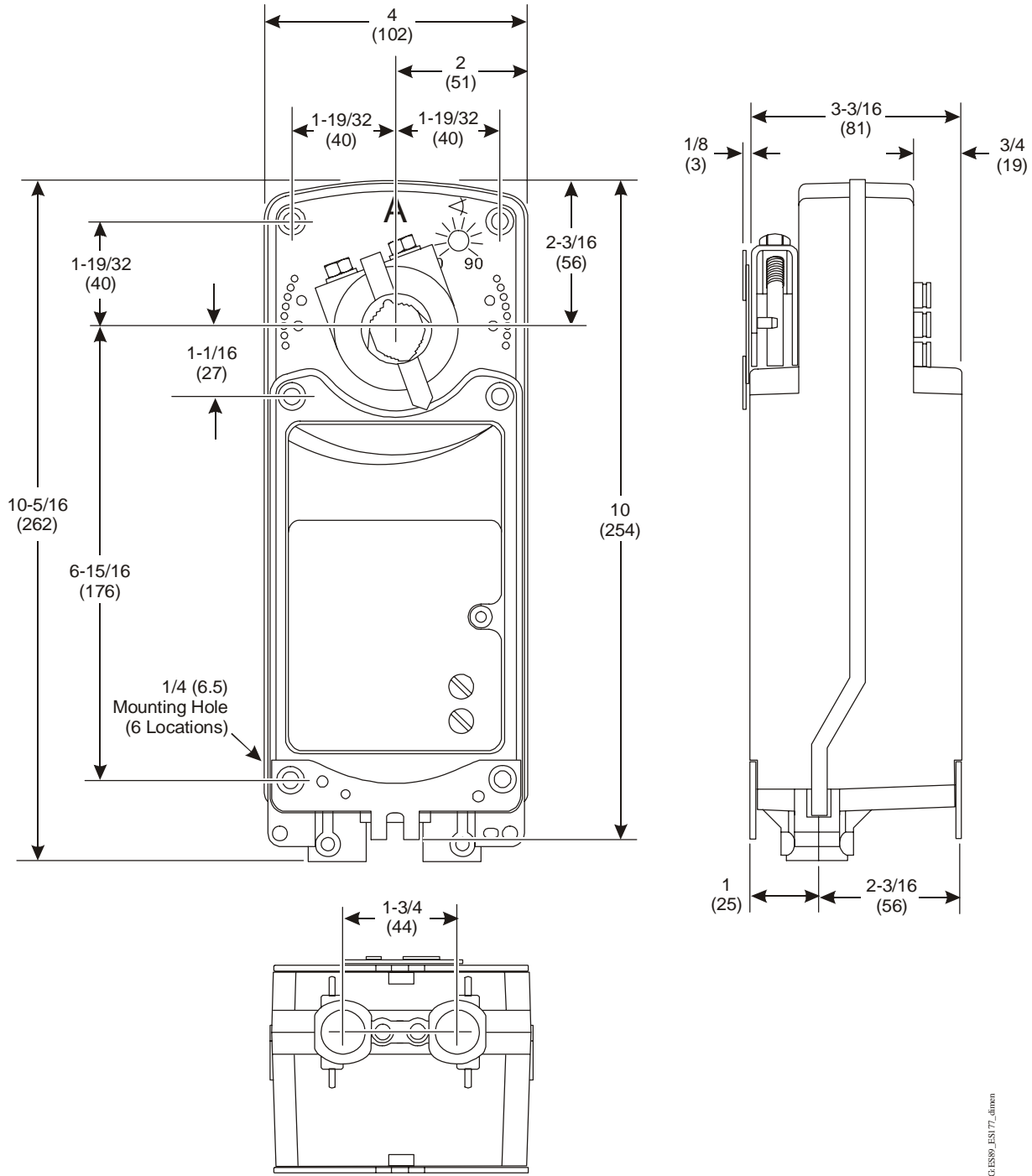

FIG.ES89\_ES177\_dimen

Figure 1: ES177B2-ZS(-S) Series Proportional Electric Spring Return Actuator Dimensions, in. (mm)

## Accessories

**Table 1: Accessories and Replacement Parts (Order Separately)**

Code Number	Description
DMPR-KC003 <sup>1</sup>	7 in. (178 mm) Blade Pin Extension (without Bracket) for Direct-Mount Damper Applications
M9000-158	Tandem Mounting Kit used to Mount Two Models of ES89/177 Series Proportional Electric Spring Return Actuators
M9000-200	Commissioning Tool that Provides a Control Signal to Drive 24 V On/Off, Floating, Proportional, and/or Resistive Electric Actuators
M9000-153	Crank arm
M9000-170	Remote Mounting Kit, Horizontal. Kit includes Mounting Bracket, M9000-153 Crank Arm, Ball Joint, and Mounting Bolts
M9000-171	Remote Mounting Kit, Vertical. Kit includes Mounting Bracket, M9000-153 Crank Arm, Ball Joint, and Mounting Bolts
M9000-320	Weather Shield Enclosure - NEMA 3R enclosure for protecting a single ES89/177 Series Actuator from rain, sleet, or snow
M9000-604	Replacement Anti-Rotation Bracket Kit (with Screws) for ES89/177 Series Proportional Electric Spring Return Actuators
M9220-600	1 in. (25 mm) Jackshaft Coupler Kit (with Locking Clip) for Mounting ES89/177 Series Proportional Electric Spring Return Actuators on Dampers with 3/4 to 1-1/16 in. or 19 to 27 mm Round Shafts, or 5/8 and 3/4 in. or 16, 18, and 19 mm Square Shafts
M9220-601	Replacement Coupler Kit (with Locking Clip) for Mounting ES89/177 Series Proportional Electric Spring Return Actuators on Dampers with 1/2 to 3/4 in. or 12 to 19 mm Round Shafts, or 3/8 and 1/2 in. or 10, 12, and 14 mm Square Shafts
M9220-602	Replacement Locking Clips for ES89/177 Series Proportional Electric Spring Return Actuators (Five per Bag)
M9220-603	Adjustable Stop Kit for ES89/177 Series Proportional Electric Spring Return Actuators
M9220-604	Replacement Manual Override Cranks for ES89/177 Series Proportional Electric Spring Return Actuators (Five per Bag)
M9220-610	Replacement Shaft Gripper, 10 mm Square Shaft with Locking Clip
M9220-612	Replacement Shaft Gripper, 12 mm Square Shaft with Locking Clip
M9220-614	Replacement Shaft Gripper, 14 mm Square Shaft with Locking Clip

1. Furnished with the damper and may be ordered separately.

## Mounting

The ES177B2-ZS(-S) Series Proportional Electric Spring Return Actuators can be easily installed on dampers with 1/2 to 3/4 in. or 12 to 19 mm round shafts, or 3/8 and 1/2 in. or 10, 12, and 14 mm square shafts. An M9220-600 Jackshaft Coupler Kit is available for 3/4 to 1-1/16 in. or 19 to 27 mm round shafts, or 5/8 and 3/4 in. or 16, 18, and 19 mm square shafts; see Table 1 for more details. If the damper shaft extends less than 3-19/32 in. (91 mm), see the *Removable Coupler* section for further instructions. If the damper shaft extends less than 1-5/32 in. (29 mm), install an extension recommended by the damper manufacturer.

### Counterclockwise (CCW) Spring Return Direction – Clockwise (CW) Powered Operation

For CCW spring return direction, mount the actuator to the damper shaft so that Side A of the actuator is away from the damper as illustrated in Figure 2. With power applied, the actuator drives CW from the 0° position and spring returns CCW.

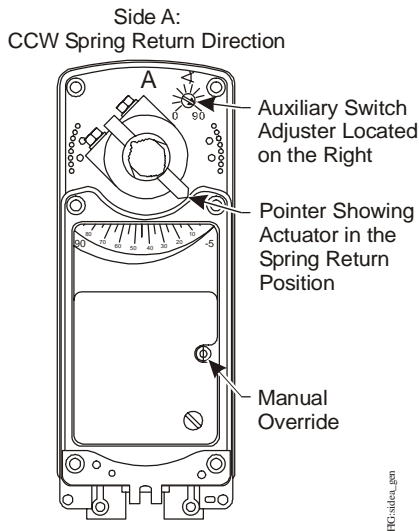

Figure 2: Side A of Actuator

### Clockwise (CW) Spring Return Direction – Counterclockwise (CCW) Powered Operation

To change the spring return direction to CW, mount the actuator to the damper shaft so that Side B of the actuator is away from the damper as illustrated in Figure 3. With power applied, the actuator now drives CCW from the 0° position and spring returns CW.

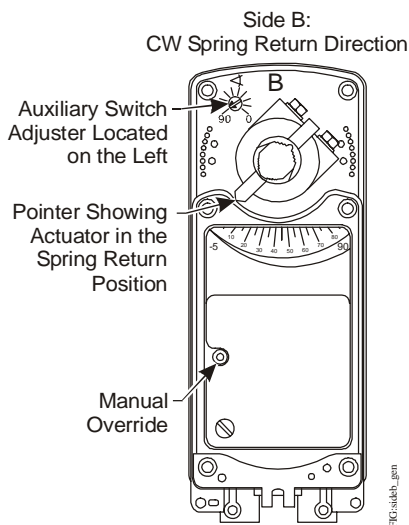

Figure 3: Side B of Actuator

### Removable Coupler

The coupler may be installed on either side of the output hub. If the damper shaft is less than 3-19/32 in. (91 mm) long, insert the coupler in the face of the actuator closest to the damper. If the damper shaft is less than 1-5/32 in. (29 mm) long, a shaft extension is required to mount the actuator.

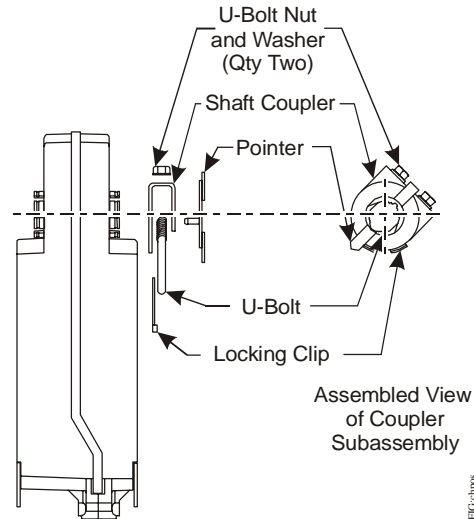

Figure 4: Changing the Position of the Coupler

To change the position of the coupler, see Figure 4 and proceed as follows:

1. Mount the coupler on either Side A or Side B of the actuator, as determined by the shaft length.
2. Snap the locking clip securely into the coupler retention groove to retain the coupler.

### Manual Override

Use only the supplied manual override crank to reposition the actuator hub when using the manual override feature.

**IMPORTANT:** Applying excessive torque to the manual override or running the manual override with a power tool may damage the internal components of the actuator and cause premature failure.

To reposition the actuator hub, proceed as follows:

1. De-energize the actuator.
2. Insert the hex end of the manual override crank into the manual override adjustment point on the face of the actuator.
3. Rotate the manual override crank in the direction indicated by the arrow on the label.

**Note:** The actuator requires 27 rotations of the manual override crank from the fully spring return position to fully reposition the actuator hub. At the end of travel, the rotational resistance increases; do not force the actuator hub past this point.

4. Rotate the manual override crank a half turn in the opposite direction to lock the actuator hub in place.

**Note:** To unlock the actuator hub, rotate the manual override crank in the direction indicated by the arrow on the label. The actuator hub automatically unlocks when power is applied to the actuator and returns the actuator to normal drive and spring return operation.

### Mounting the Actuator

To mount the actuator, proceed as follows:

1. See the dimensions in Figure 5 and Table 2 to ensure the correct positioning of the anti-rotation bracket.

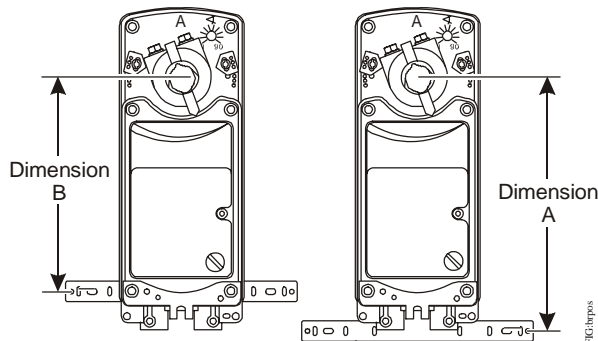

**Figure 5: Positioning the Anti-Rotation Bracket**

**Table 2: Dimensions from Anti-Rotation Bracket to Shaft Center**

Shaft Diameter	Dimension A, in. (mm)	Dimension B, in. (mm)
1/2 to 9/16 in. (12 to 14 mm)	8-9/32 (210)	7 (178)
5/8 to 3/4 in. (16 to 19 mm)	8-5/32 (207)	6-29/32 (175)

**IMPORTANT:** The tab on the anti-rotation bracket must fit midpoint in the actuator slot. Positioning the tab midpoint in the slot prevents actuator binding and premature wear, and makes actuator removal easier.

2. Bend or cut the anti-rotation bracket to fit the damper frame or duct as illustrated in Figure 6.

**Note:** The anti-rotation bracket can be bent to fit a round damper.

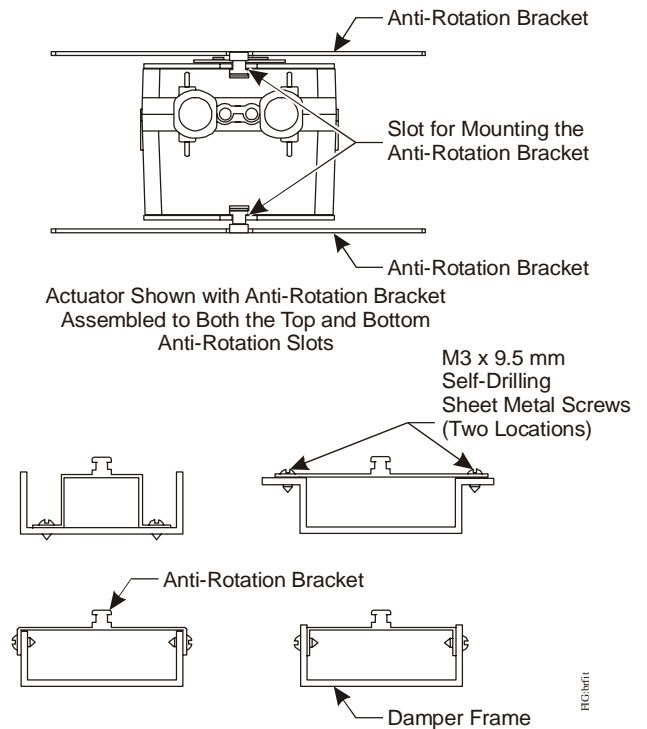

**Figure 6: Fitting the Anti-Rotation Bracket on the Damper Frame or Duct**

3. Drill mounting holes in the damper frame or duct using the anti-rotation bracket as a guide (based on the measurements obtained in Table 2 and Figure 5).
4. Secure the anti-rotation bracket to the damper frame or duct using the two M3 x 9.5 mm self-drilling sheet metal screws provided and a 1/4 in. (6 mm) blade screwdriver or 5/16 in. (8 mm) nut driver.

**IMPORTANT:** Do not overtighten the mounting screws to avoid stripping the threads. Be certain that the tab on the anti-rotation bracket remains properly positioned in the slot on the actuator, and that the actuator remains parallel to the mounting surface.

5. Slide the actuator onto the damper shaft, and position the tab of the anti-rotation bracket into the slot at the bottom of the actuator as illustrated in Figure 6.

6. Rotate the damper blades to the desired position if the power is lost. To ensure a tight seal, insert the manual override crank and turn it 5 turns in the direction indicated by the arrow on the label; the position indicator should be near the 0° position on the scale. Quickly rotate the manual override crank a half turn in the opposite direction to temporarily lock the actuator hub in place.
7. Evenly hand tighten each clamp nut onto the U-bolt, keeping the actuator flat. Secure the U-bolt to the damper shaft and tighten to a torque of 100 to 125 lb-in (11 to 14 N·m).
8. To release the spring, turn the manual override crank in the direction indicated on the label; the actuator spring returns to its starting position. If this step is omitted, the spring releases automatically when power is applied to the actuator.
9. Remove the manual override crank and store it in an unused mounting hole.
10. Apply power long enough for the actuator to travel a full stroke, and verify that the actuator rotates freely throughout the range.

**Note:** If electric power is not available, complete this verification by reinserting the manual override crank and turning it in the direction indicated to rotate the coupler to the fully open position.

### **Rotation Range Using Optional M9220 603 Adjustable Stop Kit**

The actuator is factory set for 90° rotation, and its rotation range is limited in 5° increments to a minimum of 30°. Stroke limiting stops are attached in the field to the shaft coupler side of the actuator to reduce the rotation range. Attaching a stroke limiting stop in the farthest mounting position reduces the rotation range of the actuator by 5°. Each progressive mounting position reduces the rotation range an additional 5°.

1. Check that the damper blade is accessible or that its position is permanently marked on the end of the damper shaft as illustrated in Figure 7.

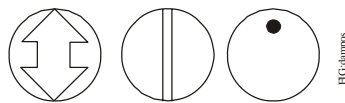

**Figure 7: Damper Position Icons**

2. Determine the desired rotation range. If a 65 to 90° rotation range is desired, add one stroke limiting stop. If a 35 to 60° rotation range is desired, add two stroke limiting stops.

**Note:** If two stroke limiting stops are applied, use the manual override crank to position and lock the actuator in a mid-stroke position to gain access to both stroke limiting stop mounting positions.

3. Mount the stroke limiting stops in the desired position using the two M4 x 10 mm self-tapping screws provided. Tighten the screws to a torque of 35 lb-in (4 N·m).
4. Manually reposition the coupler so that the coupler set screw aligns with the nodule guide that corresponds to the value determined in Step 2.

Example:

For a rotation range of 65°, mount one stroke limiting stop in the minimum stroke position as illustrated in Figure 8.

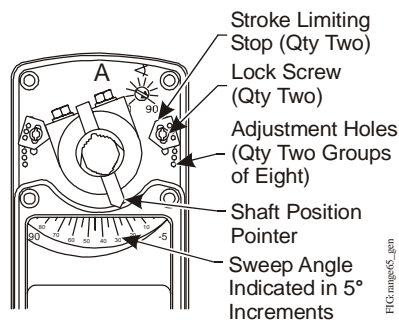

**Figure 8: One Stroke Limiting Stop Mounted in the Minimum Stroke Position for a Rotation Range of 65°**

## Wiring

The ES177B2-ZS(-S) Series Proportional Electric Spring Return Actuator provides reliable, integrated damper control. A 24 VAC at 50/60 Hz or 24 VDC input signal between the black and red wires, as well as the proper control signal, causes the output hub to rotate from -5 to 90° (unless an external mechanical limit is reached).

Once the command to rotate is removed, the actuator holds its position until either another command to rotate is applied or until all power is removed. When power is removed, the actuator spring returns to its -5° position (unless an external mechanical limit is reached). A stall condition while driving between -5 to 90° causes the output hub to stop motion and hold its position until power is removed. Rotation is mechanically limited to the -5 and 90° positions by integral end-stops. Optional end-stops are available to limit the output hub travel. An anti-rotation bracket prevents rotational movement of the actuator body.

See Figure 9 and Figure 10 for proper wiring of the ES177B2-ZS(-S) Series Proportional Electric Spring Return Actuator.



**CAUTION: Risk of Electric Shock.**  
Disconnect power supply before making electrical connections to avoid electric shock.



**CAUTION: Risk of Property Damage.**  
Do not apply power to the system before checking all wiring connections. Short circuited or improperly connected wires may result in permanent damage to the equipment.

**IMPORTANT:** Make all wiring connections in accordance with local, national, and regional regulations. Do not exceed the electrical ratings of the ES177B2-ZS(-S) Series Proportional Electric Spring Return Actuator.

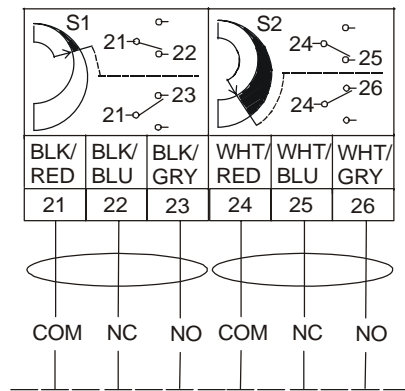

**Figure 9: Auxiliary Switch Wiring Diagram for ES177B2-ZS-S Models**

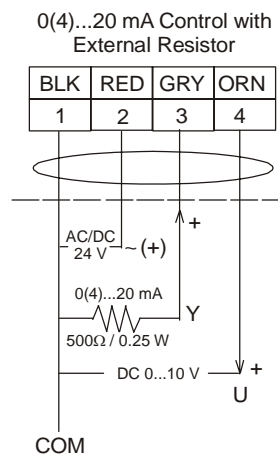
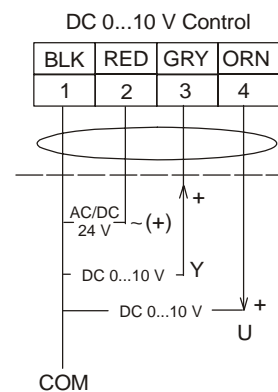

**Figure 10: Control Wiring Diagrams**

## Setup and Adjustments

### Direction of Action

The ES177B2-ZS(-S) Series Proportional Electric Spring Return Actuators are factory set for Direct Acting (DA) operation. In DA mode, applying an increasing input signal to the control input drives the actuator away from the spring return position. Reverse Acting (RA) operation is also available. In RA mode, applying an increasing input signal to the control input drives the actuator toward the spring return position. Figure 11 and Figure 12 indicate how the drive direction for the actuator depends on the spring return direction and the position of the mode selection switch.

Control Inputs				
	CCW Face of Actuator	CW Face of Actuator	Mode Selection Switch Setting	
	DA	RA	RA	DA
Increasing Signal	CW	CCW	CW	CCW
Decreasing Signal	CCW	CW	CCW	CW

Direction	Feedback	Rotation Position							
		0°*	15°	30°	45°	60°	75°	90°	
Direct Acting	0-10V	0.0V	1.7V	3.3V	5.0V	6.7V	8.3V	10.0V	
	2-10V	2.0V	3.3V	4.7V	6.0V	7.3V	8.7V	10.0V	
Reverse Acting	0-10V	10.0V	8.3V	6.7V	5.0V	3.3V	1.7V	0.0V	
	2-10V	10.0V	8.7V	7.3V	6.0V	4.7V	3.3V	2.0V	

\* 0° is the spring return position.

**Figure 11: Nominal Feedback Signal Relative to Rotation Position**

### Mode Selector Switch/RA and DA Function

The ES177B2-ZS(-S) Series Proportional Electric Spring Return Actuators are factory set at DA, 0 to 10 VDC control input.

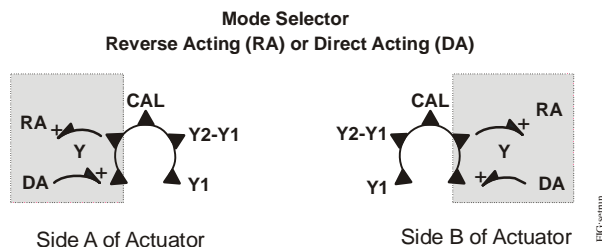
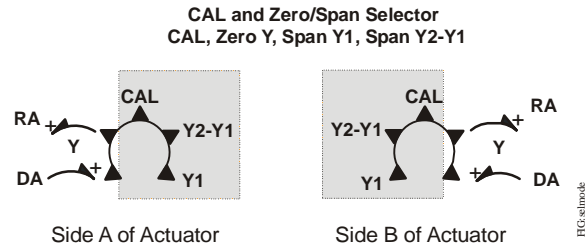

**Figure 12: Mode Selector (highlighted)**

### CAL Function

The Calibrate (CAL) function enables the actuator to redefine the selected control input range proportionally across a reduced rotation range. The actuator stores the reduced rotation range in nonvolatile memory (retains data when power is lost or removed).

The DC 0 to 10 V input signal corresponds to -5 to 90° rotation. If the rotation range is reduced, the end-stop is reached with a reduced input signal. For example, if a DC 0 to 10 V input signal is selected and the rotation range is limited to 75°, the end-stop is reached at DC 8.3 V. After calibration, the end-stop is reached at DC 10 V.



**Figure 13: CAL Operation Setup (highlighted)**

To calibrate the control input range, proceed as follows:

1. With power off, move the mode selection switch to the CAL position (Figure 13). Then, energize the actuator. The actuator automatically rotates until the end-stops are found and proportionally reconfigures the control input range to the reduced rotation range.
  2. Return the mode selection switch to the desired selection (example: DA).
- Note:** During normal operation, if the actuator stroke increases due to seal or seat wear, the input is redefined to the increased rotation range in approximately 0.5° increments.
3. If the actuator mounting position is changed or if the linkage is adjusted, repeat Steps 1 and 2 to reinitiate the CAL function.

**Note:** To repeat calibration with power applied, move the mode selection switch out of the CAL position for at least 2 seconds before returning it to the CAL position. Auto calibration begins 5 seconds after you return it to the CAL position.

### Setting the Zero (Y1) and Span Voltages (Y2-Y1)

The command voltage value for a minimum hub angle (the zero setting) and the change in command value required to travel the total hub angle (the span) are adjustable (Figure 13). These settings are with respect to the minimum hub angle and the total travel distance defined during the CAL function. If the actuator is powered on, the Span voltage can be set right after the Zero voltage is set without first powering down the actuator.

#### Setting the Zero (Y1) Voltage

To set the Zero (Y1) voltage:

1. With power off, set the mode selector switch (Figure 13) to the zero (Y1) position.
2. Energize the actuator.
3. Adjust the voltage switch (Figure 14) to the desired zero voltage as displayed on the printed 0-10 scale. To inspect the exact setting voltage, attach a voltmeter between the feedback wires (orange [+] and black [common]).
4. Set the mode selector switch to the RA or DA position. The zero voltage setting is now stored.

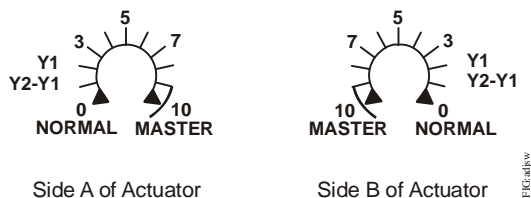

Figure 14: Potentiometer Adjustment for Setting Span and Zero Voltage

#### Setting the Span (Y2-Y1) Voltage

To set the Span (Y2-Y1) voltage:

1. With power off, set the mode selection switch to the span (Y2-Y1) position.
2. Energize the actuator.
3. Adjust the voltage potentiometer switch to the desired span voltage as displayed on the printed 0-10 scale. To inspect the exact setting voltage, attach a voltmeter to the feedback wire.
4. Set the mode selection switch to the RA or DA position. The span voltage setting is now stored.

### Inspecting the Zero (Y1) and Span (Y2-Y1) Voltages

When the actuator is powered up, moving the switch to the zero or span position does not change the saved zero or span setting. Instead, this causes the exact Y1, Y2-Y1 voltage values to be displayed on the feedback (orange) wire.

#### Inspecting the Zero (Y1) Voltage Setting

To inspect the Zero (Y1) voltage setting:

1. Energize the actuator and set the mode selection switch to the zero (Y1) position. Attach a voltmeter between the feedback wires (orange [+] and black [common]). Read the voltage setting.
2. Set the mode selection switch to the RA or DA position.

#### Inspecting the Span (Y2-Y1) Voltage Setting

To inspect the Span (Y2-Y1) voltage setting:

1. Energize the actuator and set the mode selection switch to the span position. Attach a voltmeter between the feedback wires (orange [+] and black [common]). Read the voltage setting.
2. Set the mode selection switch to the RA or DA position.

### Tandem Operation: ES177B2-ZS(-S) Series Master with ES177B2(-S) Series Slaves

**Note:** The zero and span voltage settings must be completed before configuring actuators for tandem operation. If changes are required after the actuators are configured for tandem operation, remove power from the actuators and disconnect the master ES177B2-ZS(-S) Series feedback wire from the slave ES177B2(-S) Series actuator wire. This prevents the slave actuator from responding to setup values on the feedback wire. See [Setting the Zero \(Y1\) and Span Voltages \(Y2-Y1\)](#).

The tandem configuration (Figure 15 and Figure 16) provides twice (with two actuators) or triple (with three actuators) the running and spring return torque of a single actuator (354 lb-in [40 N·m], 531 lb-in [60 N·m]). One ES177B2(-S) Series actuator may be mounted in tandem with one ES177B2-ZS(-S) Series model using the M9000-158 Tandem Mounting Kit. To mount a third actuator, user-configured bracketing is required.

### DC 0...20 V Control with Tandem Connection

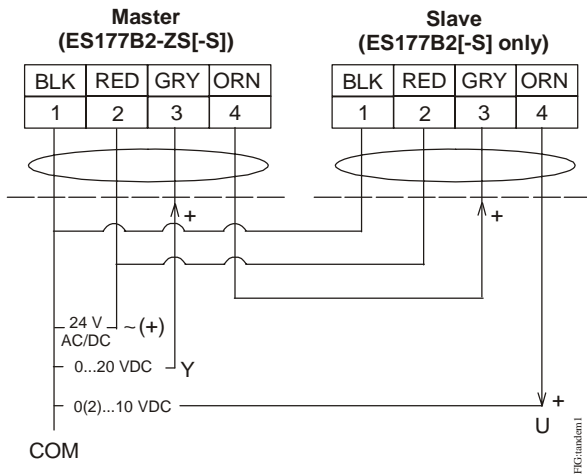

**Figure 15: Tandem Connection**

Follow these guidelines for tandem operation:

- One ES177B2-ZS(-S) Series actuator and one or two ES177B2(-S) Series actuators may be operated in tandem on the same shaft. If mounting two actuators, see Figure 15; for three actuators, see Figure 16.
- Each actuator requires separate 24 V power. When two or more actuators connected in tandem share a common power source, the total maximum power draw is actually 1.5 times the normal running current for each actuator. (Total Power = Number of Actuators x Running Power x 1.5)

- The ES177B2-ZS(-S) Series actuator must be configured as the master by setting the adjustment potentiometer to the master position.
- The other ES177B2(-S) Series actuator(s) must be configured as slave(s) by setting the Mode Selector switch to the slave position.
- The master accepts DC 0 to 20 V command signals as programmed for zero and span operation.
- The master and slave(s) must have matching RA/DA settings.
- The master and slave(s) must spring return in the same direction.
- Once tandem-operating actuators are mounted to a common or linked shaft, manual override is no longer an available function.

The feedback wire of the master (orange) is connected to the command wire(s) of the slave(s) (gray). As the master moves in response to position commands, the master sets its feedback wire to 0 V if moving clockwise, 5 V if holding, or 10 V if moving counterclockwise.

Each slave actuator must have its function switch set on the slave setting. Its gray command wire must be connected to the master's orange feedback wire.

Position information, DC 0(2) to 10 V, is available on the slave actuator(s) feedback wire (orange).

### DC 0...20 V Control with Multiple Slaves

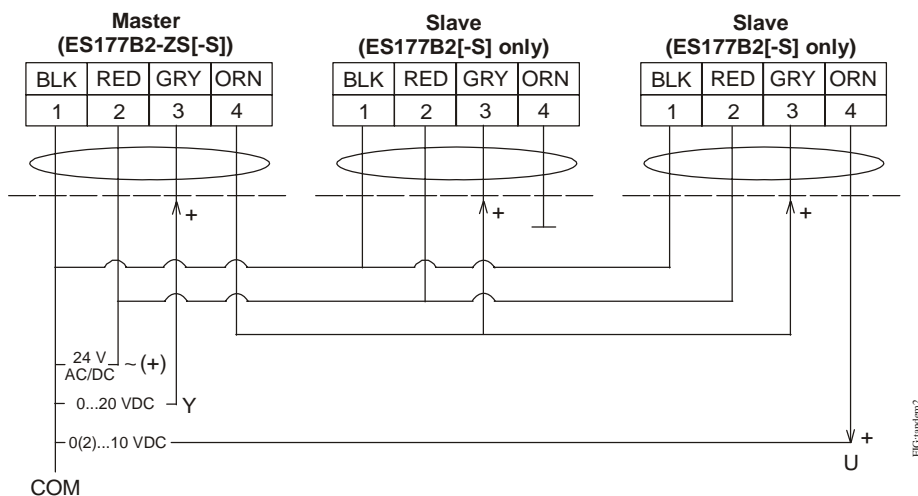

**Figure 16: Tandem Connection - Three Actuators**

### **Energizing Master (DHF1) and Slave (DFM1) Actuator(s)**

Before energizing the actuators, the zero and span voltage settings must be complete on the master actuator. See [Setting the Zero \(Y1\) and Span Voltages \(Y2-Y1\)](#).

1. Place the master (ES177B2-ZS[-S] Series) mode selector to the desired RA/DA position.
2. Place the master (ES177B2-ZS[-S] Series) adjustment potentiometer at the 10 V setting, labeled Master, to set the actuator in the Master mode.
3. Place the slave (ES177B2[-S] Series) mode selector switch in slave mode position (refer to the *ES177B2(-S) Series Proportional Electric Spring Return Actuators Installation Instructions [Part No. 34-636-1875]*).
4. Connect the master feedback wire to the slave's command wire.
5. Connect the master command wire to the host command signal wire. Connect the slave feedback signal wire to the host system's feedback wire.
6. Energize the master and slave actuator.

**Note:** Make sure all switch settings for the master/slave configuration are completed properly. If the switches are set incorrectly, the actuators may appear to work satisfactorily, but excessive gear movement may result, which greatly reduces the unit's life expectancy.

### **Resetting Factory Defaults for an ES177B2-ZS(-S) Series Actuator**

To reset an ES177B2-ZS(-S) Series actuator to the factory default condition:

1. Remove power from the actuator.
2. Connect the ES177B2-ZS(-S) Series Command (gray) wire to its own Feedback (orange) wire.
3. Energize the ES177B2-ZS(-S) Series actuator.
4. Wait 5 seconds.
5. Remove power from the actuator.
6. Disconnect the ES177B2-ZS(-S) Series Command (gray) wire to its own Feedback (orange) wire.
7. Proceed with normal installation.

### **Auxiliary Switches (ES177B2-ZS-S Models Only)**

The ES177B2-ZS-S models include two integral auxiliary switches with a switch adjuster accessible on either face of the actuator (as illustrated in Figure 2 and Figure 3). The nominal factory setting for Auxiliary Switch No. 1 is 11° closing, and the nominal factory setting for Auxiliary Switch No. 2 is 81° opening (relative to a 0 to 90° rotation range). See the [Technical Specifications](#) table for the auxiliary switch ratings.



#### **WARNING: Risk of Electric Shock.**

Disconnect each of multiple power supplies before making electrical connections. More than one disconnect may be required to completely de-energize equipment. Contact with components carrying hazardous voltage can cause electric shock and may result in severe personal injury or death.

The switch point of Auxiliary Switch No. 1 is fixed. The switch point of Auxiliary Switch No. 2 is independently and continuously adjustable from 25 to 95°. See Figure 17 and use the method in the following steps for the most accurate positioning of Auxiliary Switch No. 2.

To change the switch point of Auxiliary Switch No. 2, proceed as follows:

1. Position the actuator in the full spring return position.

**Note:** Auxiliary Switch No. 2 is factory set to trip when the actuator reaches the 81° position.

2. Rotate the switch adjuster until it points to the desired switch point.

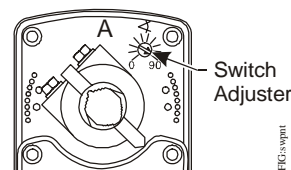

**Figure 17: Switch Point Settings**

3. Connect Auxiliary Switch No. 2 to a power source or an ohmmeter, and apply power to the actuator. The actuator moves to the fully open position and holds while power is applied.
4. Observe the switch point. If required, repeat Steps 2 and 3.

## Repair Information

A number of replacement parts are available; see Table 1 for more details. If the ES177B2-ZS(-S) Series Proportional Electric Spring Return Actuator fails to operate within its specifications, replace the unit. For a replacement electric actuator, contact the nearest Dodge Engineering & Controls representative.

## Technical Specifications

### ES177B2-ZS(-S) Series Proportional Electric Spring Return Actuators (Part 1 of 2)

<b>Power Requirements</b>		AC 24 V (AC 19.2 to 30 V) at 50/60 Hz: Class 2 (North America) or Safety Extra-Low Voltage (SELV) (Europe), 15.6 VA Running, 7.5 VA Holding Position; DC 24 V (DC21.6 to 26.4 V): Class 2 (North America) or SELV (Europe), 6.8 W Running, 2.9 W Holding Position
<b>Transformer Sizing Requirements</b>		20 VA Minimum per Actuator
<b>Input Signal/Adjustments</b>		Factory Set DC 0 to 10 V, CW Rotation with Signal Increase; Selectable DC 0 to 10 V or 0 to 20 mA with Field Furnished 500 ohm, 0.25 W minimum resistor; Start Point Programmable DC 0 to 10 V; Span Programmable DC 2 to 10 V; Switch Selectable Direct or Reverse Action with Signal Increase
<b>Control Input Impedance</b>		Voltage Input: 200,000 ohms; Current Input: 500 ohms with Field Furnished 500 ohm Resistor
<b>Feedback Signal</b>		0 to 10 VDC for Desired Rotation Range up to 90°; Corresponds to Rotation Limits, 500 mA maximum
<b>Auxiliary Switch Rating</b>	<b>ES177B2-ZS-S Models</b>	Two Single-Pole, Double-Throw (SPDT), Double-Insulated Switches with Gold Flash Contacts: 24 VAC, 50 VA Pilot Duty; 120 VAC, 5.8 A Resistive, 1/4 hp, 275 VA Pilot Duty; 240 VAC, 5.0 A Resistive, 1/4 hp, 275 VA Pilot Duty
<b>Spring Return</b>		Direction is Selectable with Mounting Position of Actuator: Side A, Actuator Face Away from Damper for CCW Spring Return; Side B, Actuator Face Away from Damper for CW Spring Return
<b>Running and Spring Return Torque</b>		177 lb-in (20 N-m) for a Single Actuator; 354 lb-in (40 N-m) for Two Like Models Mounted in Tandem; 531 lb-in (60 N-m) for Three Like Models Mounted in Tandem
<b>Rotation Range</b>		Adjustable from 30 to 90° CW or CCW with Optional M9220-603 Adjustable Stop Kit; Mechanically Limited to 90°
<b>Rotation Time</b>	<b>Power On (Running)</b>	150 Seconds for 0 to 177 lb-in (0 to 20 N-m) at All Operating Conditions; Independent of Load
	<b>Power Off (Spring Returning)</b>	20 Seconds for 0 to 177 lb-in (0 to 20 N-m) at Room Temperature
<b>Cycles</b>		60,000 Full Stroke Cycles; 1,500,000 Repositions
<b>Audible Noise Rating</b>	<b>Power On (Running)</b>	<40 dBA at 39-13/32 in. (1 m)
	<b>Power On (Holding)</b>	<20 dBA at 39-13/32 in. (1 m)
	<b>Power Off (Spring Returning)</b>	<55 dBA at 39-13/32 in. (1 m)

## ES177B2-ZS(-S) Series Proportional Electric Spring Return Actuators (Part 2 of 2)

<b>Electrical Connections</b>	<b>Actuator (All Models)</b>	48 in. (1.2 m) Halogen-Free Cable with 18 AWG (0.75 mm <sup>2</sup> ) Wire Leads
	<b>Auxiliary Switches (ES177B2-ZS-S Models)</b>	48 in. (1.2 m) Halogen-Free Cable with 18 AWG (0.75 mm <sup>2</sup> ) Wire Leads
<b>Conduit Connections</b>		Integral Connectors for 3/8 in. Flexible Metal Conduit
<b>Mechanical Connections</b>	<b>Standard Shaft Clamp Included with Actuator</b>	1/2 to 3/4 in. or 12 to 19 mm Diameter Round Shafts, or 3/8 and 1/2 in. or 10, 12, and 14 mm Square Shafts
	<b>Optional M9220-600 Jackshaft Coupler Kit</b>	3/4 to 1-1/16 in. or 19 to 27 mm Diameter Round Shafts, or 5/8 and 3/4 in. or 16, 18, and 19 mm Square Shafts
<b>Aluminum Enclosure</b>		NEMA 2 (IP54) for All Mounting Orientations
<b>Ambient Conditions</b>	<b>Operating</b>	-40 to 131°F (-40 to 55°C); 90% RH Maximum, Noncondensing
	<b>Storage</b>	-85 to 185°F (-65 to 85°C); 95% RH Maximum, Noncondensing
<b>Dimensions</b>		See Figure 1.
<b>Compliance</b>	<b>United States</b>	UL Listed, CCN XAPX, File E191697; to UL 60730-1A: Automatic Electrical Controls for Household and Similar Use; and UL 60730-2-14: Part 2, Particular Requirements for Electric Actuators.
	<b>Canada</b>	UL Listed, CCN XAPX7, File E191697; to CAN/CSA-E60730-1: Automatic Electrical Controls for Household and Similar Use.
	<b>Europe</b>	CE Mark, EMC Directive 89/336/EEC (All Models)
		CE Mark, Low Voltage Directive 73/23/EEC (ES177B2-ZS-S Models)
<b>Australia and New Zealand</b>	C-Tick Mark, Australia/NZ Emissions Compliant (All Models)	
<b>Shipping Weight</b>		6.4 lb (2.9 kg)

The performance specifications are nominal and conform to acceptable industry standards. For application at conditions beyond these specifications, consult the local Dodge Engineering & Controls office. Dodge Engineering & Controls, Inc. shall not be liable for damages resulting from misapplication or misuse of its products.



**DODGE ENGINEERING  
& CONTROLS, INC.**

**Dodge Engineering & Controls, Inc.**  
196 Riverneck Road  
Chelmsford, MA 01824

1-978-244-1200 or 1-877-DEI-CTRL (Toll Free)  
1-978-244-1422 (Fax)