



DODGE ENGINEERING & CONTROLS, INC.

TEL: (978) 244-1200 FAX: (978) 244-1422

www.DEIcontrols.com

USFT-B Series Liquid Ultrasonic Flow Transmitters

Loop Powered 4-20 mA Output, Flows to 400 GPM, 3/4" to 3" Pipe, Brass

DESCRIPTION

DEI USFT-B Ultrasonic Flowmeters are ideal for measurement of flow rates of acoustically conductive liquids including most clean liquids and many liquids with entrained solids.

Main advantages include excellent long term stability, no pressure drop, broad fluid compatibility, high accuracy and low cost. Model USFT-B has no moving parts.

At the heart of Series USFT-B is a proprietary mixed signal ASIC which allows sophisticated timing, control and transducer drive circuitry to be combined on a single integrated circuit. The ASIC uses a special algorithm that is an improvement upon the standard single-path measurement technique. Using the "sing around" method, the ultrasonic transducer alternates between transmitting and receiving to measure differences in flight time between upstream and downstream transmissions. A sound pulse is transmitted from an upstream transducer towards a downstream transducer like a traditional time-of-flight measurement. However, the received sound pulse then triggers a second downstream transmission that then triggers a third and so on for a specific number of cycles. This process is repeated in the upstream direction.

Because it takes an average flight time over multiple cycles to compute the difference in flight times, the approach yields a significant improvement in timing accuracy when compared with the time-of-flight difference of a single sound pulse in each direction. This algorithm, combined with the pico-second timing resolution of the ASIC, provides the precise time measurement capability necessary for compact, small diameter ultrasonic meters.

The output of model USFT-B is unaffected by changes in fluid temperature, density and viscosity as the flow calculation is independent of the speed of sound.

Wetted materials include ULTEM® encapsulated ultrasonic transducers with a choice of elastomer seals and Brass body material.

SPECIFICATIONS

GENERAL

Flow Range: Bi-directional, field selectable per "Standard Models" table

Accuracy: ±0.75% of full scale

Operating Temperature: -40 to 190°F (-40 to 87.8°C)

Response Time: User Selectable, 2 or 10 seconds

Viscosity Range: 0.2 to 150 cSt (0.2 to 150 mPa·s)

Liquid Density: 30.6 to 74.9 lb/cu.ft. (490 to 1200 kg/m³)

Max. Working Pressure: 250 PSI

Pipe Sizes: 3/4", 1", 1 1/2", 2", 3"

Pipe Connections:

Sizes 3/4" to 2" - Female NPT, BSP

Size 3": ASME 150 or DIN 16 Flange

Electrical Enclosure: Integral to Body casting with gasketed cover; One 1/2" NPT conduit connection (plugged when model ordered with metric threads) and one M16 x 1.5 connection (plugged when model ordered with NPT threads)

Electrical Connections: Screw terminal connections on PC board

Enclosure Rating: NEMA 4 (IP 65)

Power: 18 to 36 VDC

WETTED MATERIALS

Ultrasonic Transducers: ULTEM® Encapsulated

Seals: EPDM, Buna-N, Neoprene™, FKM, or other

Body Material: Brass (UNS C83600)

OUTPUT

Analog: 2-wire, 4-20 mA output; Output is 4 mA from zero to min. flow (see Standard Model table)

Error Detection: An optically isolated sink output is activated under certain detectable fault conditions, such as transducer failure or overly noisy output due to flow stream anomalies, as might be seen due to excessive bubble entrainment. The optional Fault output is an optically isolated NPN transistor capable of sinking up to 10 mA from a voltage source of no more than 48 VDC.

Direction of Flow: Optional output to indicate direction of flow is available. Activation or deactivation of an optically isolated 10 mA (max. 48V no load voltage) sink output indicates flow direction. Error detection is not available when this option is ordered.

LOOP RESISTANCE Vs SUPPLY VOLTAGE

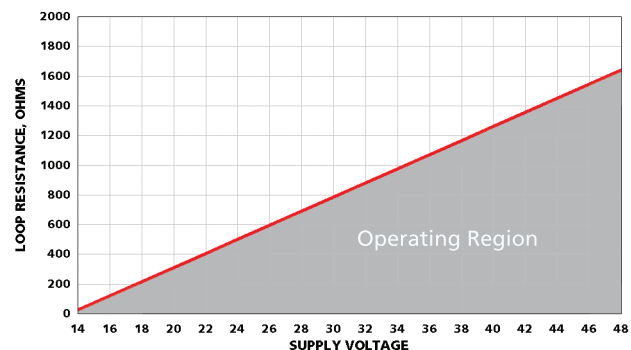

DIMENSIONS

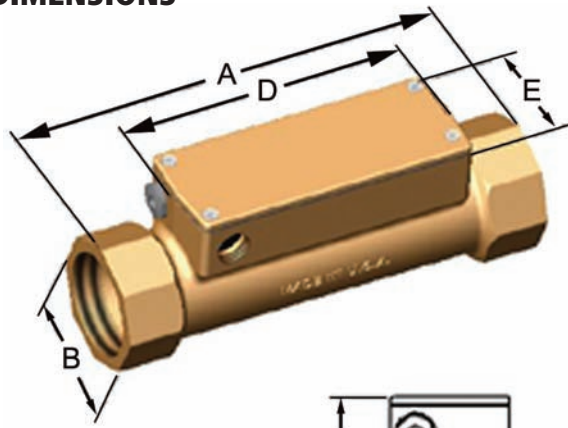

Pipe sizes 3/4" to 2"

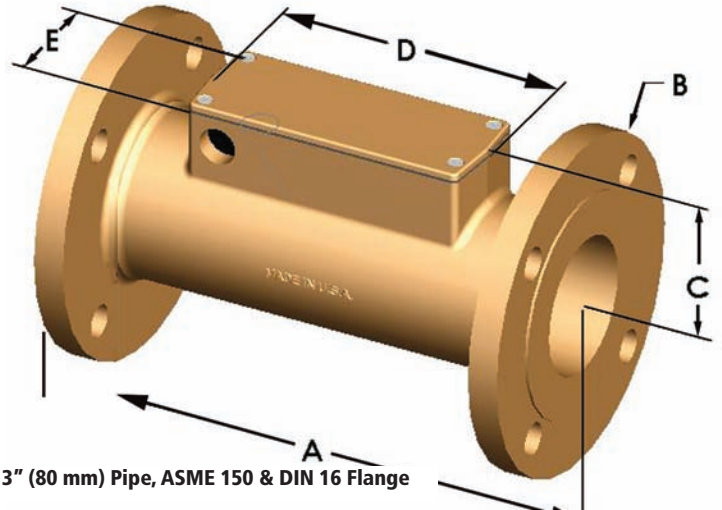
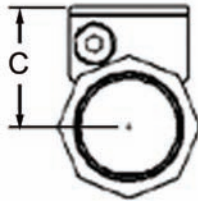

3" (80 mm) Pipe, ASME 150 & DIN 16 Flange

Size/Connection	A		B		C		D		E	
	Inches	mm	Inches	mm	Inches	mm	Inches	mm	Inches	mm
3/4" & 1"	9.20	234	1.62	41.10	2.06	52.30	6.40	163	2.40	61.00
1-1/2" & 2"	9.88	251	2.75	69.90	2.51	63.80	6.40	163	2.40	61.00

Size/Connection	A		B		C		D		E	
	Inches	mm	Inches	mm	Inches	mm	Inches	mm	Inches	mm
3" ASME 150	11.00	-	Ø 7.50	-	3.16	-	6.50	-	2.50	-
80 mm DIN 16	-	280	-	190	-	84.00	-	165	-	63.50

STANDARD MODELS

Model	Pipe Size/Thread Size	*Field Selectable Full Scale Ranges (GPM)		*Field Selectable Full Scale Ranges (LPM)		
		Min.	Max	Min.	Max	
USFT-B-.75	3/4" NPT or BSP	L	0.23	15	0.90	60
		H	0.38	25	1.50	100
USFT-B-1.0	1.0" NPT or BSP	L	0.45	30	1.70	115
		H	0.75	50	3.00	200
USFT-B-1.5	1.50" NPT or BSP	L	0.60	40	2.30	150
		H	1.20	80	4.50	300
USFT-B-2.0	2.0" NPT or BSP	L	0.90	60	3.40	225
		H	1.80	120	6.80	455
USFT-B-3.0	3" ASME Class 150 Flange 80 mm DIN Class 150 Flange	L	3.00	200	11.00	750
		H	6.00	400	23.00	1500

*Other F.S. ranges can be specified

ORDERING INFORMATION

ORDER NUMBER (ABCDE)

Example: USFT-B-1.0NGB

A Model	B Pipe Thread	C Units of Measure	D Transducer Seal	E Options
USFT-B-.75 USFT-B-1.0 USFT-B-1.5 USFT-B-2.0 USFT-B-3.0	3/4" to 2" N= Female NPT B=Female British Standard Pipe (G) 3" A= ASME Class 150 Flange D= DIN Class 150 Flange	G= Gallons Per Minute (U.S.) L= Liters Per Minute	E=EPDM B= Buna-N N= Neoprene® V= FKM	DF= Direction of flow output option
*For non-listed ranges specify model followed by full span value Example: USFT-B-1.5-50G = 50 GPM at 20 mA or USFT-B-1.5-200L=200LPM @ 20 mA				

ULTEM® is a registered trademark of The General Electric Company

Neoprene® is a registered trademark of DuPont Dow

DEI reserves the right to make design changes without prior notice.