



*Close-Off Pressures
Normally Closed*

				ELECTRIC ZONE (GZ & GT)			ELECTRIC LINEAR (GS & GF)		LOW PRESSURE PNEUMATIC (20 PSI)			
GZ & GT Valves	GS & GF Valves	Size	Cv (Kvs)	ENZ2B2, ENZ2C2	ENZ3B2 & ESZ3B2 ENZ3C2 & ESZ3C2	ENZ1B2 & ESZ1B2	ESL3B2, ESL3C2 & ENL3C2	ESL1B2, ENL1C2 & ESL1C2 ESL2B2, ENL2C2 & ESL2C2	2" Actuator: PS2 (GZ & GT Valves)	4" Actuator: PS4	8" Actuator: PS8	12" Actuator: PS12
•	—	½"	0.4 (0.34)	70 (483)	95 (655)	95 (655)	—	—	120 (827)	—	—	—
•	—	½"	0.63 (0.54)	70 (483)	95 (655)	95 (655)	—	—	120 (827)	—	—	—
•	•	½"	1 (0.86)	70 (483)	95 (655)	95 (655)	250 (1724)	250 (1724)	120 (827)	236 (1627)	250 (1724)	—
•	•	½"	1.6 (1.37)	70 (483)	95 (655)	95 (655)	250 (1724)	250 (1724)	120 (827)	236 (1627)	250 (1724)	—
•	•	½"	2.5 (2.14)	40 (276)	50 (345)	50 (345)	250 (1724)	250 (1724)	65 (448)	236 (1627)	250 (1724)	—
•	•	½"	4 (3.43)	40 (276)	50 (345)	50 (345)	250 (1724)	250 (1724)	65 (448)	236 (1627)	250 (1724)	—
•	•	¾"	6.3 (5.40)	30 (207)	40 (276)	40 (276)	250 (1724)	250 (1724)	50 (345)	155 (1069)	250 (1724)	—
•	•	1"	10 (9)	30 (207)	40 (276)	40 (276)	203 (1400)	250 (1724)	50 (345)	91 (627)	250 (1724)	—
—	•	1- 1/4"	16 (14)	—	—	—	117 (807)	250 (1724)	—	52 (359)	148 (1020)	—
—	•	1- 1/2"	25 (21)	—	—	—	73 (503)	208 (1433)	—	32 (221)	92 (634)	—
—	•	2"	40 (34)	—	—	—	44 (303)	126 (869)	—	20 (138)	55 (379)	—
—	•	2- 1/2"	63 (54)	—	—	—	34 (234)	97 (668)	—	—	36 (248)	114 (785)
—	•	3"	100 (86)	—	—	—	22 (152)	63 (434)	—	—	23 (158)	74 (510)
—	•	4"	160 (137)	—	—	—	—	39 (268)	—	—	—	46 (317)
—	•	5"	250 (214)	—	—	—	—	25 (172)	—	—	—	29 (199)
—	•	6"	400 (343)	—	—	—	—	17 (117)	—	—	—	20 (138)

Notes:

- For 3-way valve close-offs, use both charts to determine upper port (NC) and bottom port (NO).
- Table expressed in psi (kPa).



Close-Off Pressures Normally Open

				ELECTRIC ZONE (GZ & GT)			ELECTRIC LINEAR (GS & GF)		LOW PRESSURE PNEUMATIC (20 PSI)			
GZ & GT Valves	GS & GF Valves	Size	Cv (Kvs)	ENZ2B2 & ENZ2C2	ENZ3B2 & ESZ3B2 ENZ3C2 & ESZ3C2	ENZ1B2 & ESZ1B2	ESL3B2, ESL3C2 & ENL3C2	ESL1B2, ENL1C2 & ESL1C2 ESL2B2, ENL2C2 & ESL2C2	2" Pneumatic: PS2 (GZ & GT Valves)	4" Pneumatic: PS4	8" Pneumatic: PS8	12" Pneumatic: PS12
•	-	½"	0.4 (0.34)	60 (414)	120 (828)	160 (1103)	-	-	85 (586)	-	-	-
•	-	½"	0.63 (0.54)	60 (414)	120 (828)	160 (1103)	-	-	85 (586)	-	-	-
•	•	½"	1 (0.86)	60 (414)	120 (828)	160 (1103)	250 (1724)	250 (1724)	85 (586)	142 (979)	250 (1724)	-
•	•	½"	1.6 (1.37)	60 (414)	120 (828)	160 (1103)	250 (1724)	250 (1724)	85 (586)	142 (979)	250 (1724)	-
•	•	½"	2.5 (2.14)	35 (242)	65 (448)	85 (586)	250 (1724)	250 (1724)	45 (310)	142 (979)	250 (1724)	-
•	•	½"	4 (3.43)	35 (242)	65 (448)	85 (586)	250 (1724)	250 (1724)	45 (310)	142 (979)	250 (1724)	-
•	•	¾"	6.3 (5.40)	30 (207)	55 (379)	70 (482)	250 (1724)	250 (1724)	35 (241)	80 (552)	231 (1593)	-
•	•	1"	10 (9)	30 (207)	55 (379)	70 (482)	201 (1386)	250 (1724)	35 (241)	52 (359)	150 (1034)	-
-	•	1- 1/4"	16 (14)	-	-	-	124 (855)	250 (1724)	-	32 (221)	93 (641)	-
-	•	1- 1/2"	25 (21)	-	-	-	80 (552)	250 (1724)	-	20 (138)	60 (414)	-
-	•	2"	40 (34)	-	-	-	49 (338)	201 (1386)	-	12 (83)	37 (255)	187 (1288)
-	•	2- 1/2"	63 (54)	-	-	-	38 (267)	153 (1054)	-	-	31 (213)	95 (655)
-	•	3"	100 (86)	-	-	-	25 (172)	101 (696)	-	-	20 (138)	63 (434)
-	•	4"	160 (137)	-	-	-	-	65 (448)	-	-	-	40 (275)
-	•	5"	250 (214)	-	-	-	-	42 (289)	-	-	-	26 (179)
-	•	6"	400 (343)	-	-	-	-	29 (200)	-	-	-	18 (124)

Notes:

- For 3-way valve close-offs, use both charts to determine upper port (NC) and bottom port (NO).
- Table expressed in psi (kPa).

Submittal Sheet

ENZ2B2 Valve Actuator, 24 Vac Proportional Control

The ENZ2B2 Electronic Valve Actuator requires a 24 Vac supply and receives a 0 to 10 Vdc control signal to proportionally control a valve. This actuator is designed to work with GZ Series Zone Valves with a 7/32-inch (5.5 mm) stroke and a threaded valve bonnet that fits the actuator.

Wiring Diagram

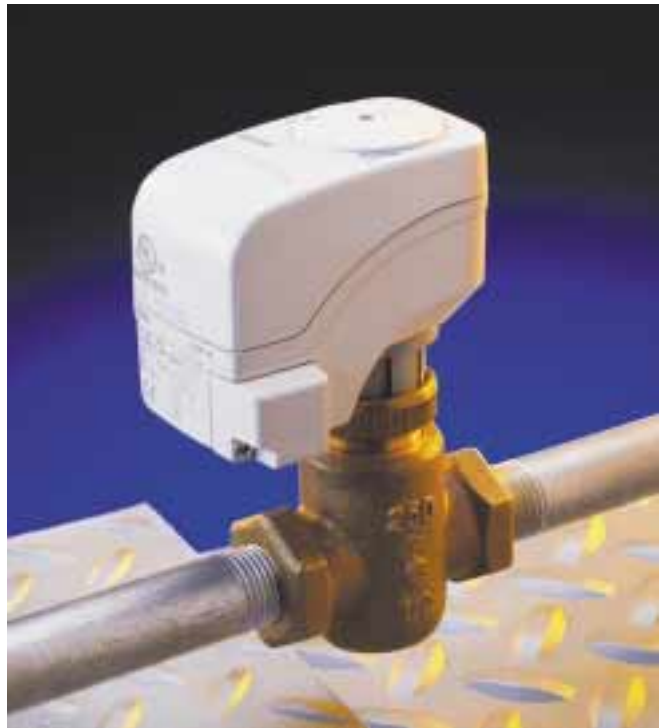
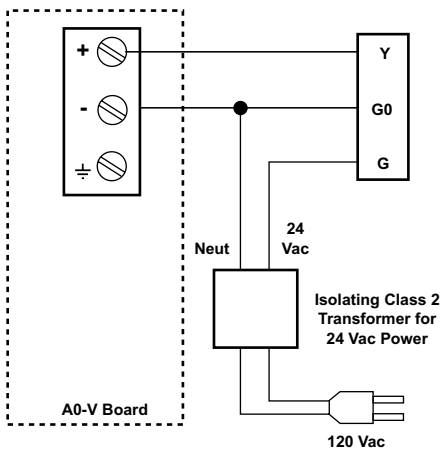

Part No.	Description	Part No.	Fail
	0 to 10	ENZ2B2	In-Place

Dimensions				
Valve Line Size	Center Line to Top of Actuator	Service Height	Actual Width	Service Width
	H ¹	H	W ¹	W
1/2" (15 mm)	4-1/2" (115 mm)	12" (300 mm)	3-1/4" (83 mm)	11" (275 mm)
3/4" (20 mm)	4-1/2" (115 mm)	12" (300 mm)	3-1/4" (83 mm)	11" (275 mm)
1" (25 mm)	4-3/4" (121 mm)	12" (300 mm)	3-1/4" (83 mm)	11" (275 mm)

Specifications

Operating Voltage 24 Vac ± 20% or 24 Vdc ± 25%
 Frequency 50/60 Hz
 Power Consumption 2.0 VA
 Function
 Running Time 75 sec.
 Nominal Stroke 7/32" (5.5 mm)
 Nominal Force 45 lb. (200 N)
 Agency Approvals UL873
 CSA C22.2 No. 24-93
 Ambient Temperature
 Operation 34 to 122°F (1 to 50°C)
 Transport and Storage -13 to +158°F (-25 to +70°C)
 Medium Temperature 34 to 230°F (1 to 110°C)
 Mounting Location NEMA 1 (interior only)

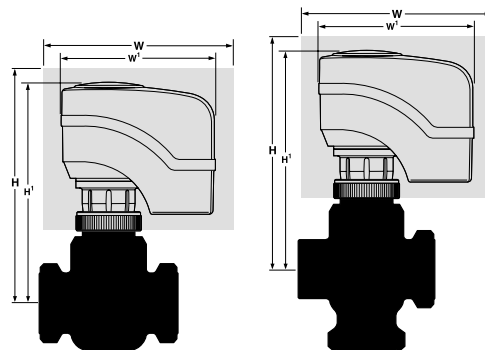

Submittal Sheet

ENZ2C2 Valve Actuator, 24 Vac 3-position (floating) Control

The ENZ2C2 Electronic Valve Actuator requires a 24 Vac supply floating control signal to provide three-position control. This actuator is designed to work with GZ Series Zone Valves with a 7/32-inch (5.5 mm) stroke and a threaded valve bonnet that fits the actuator.

Wiring Diagram

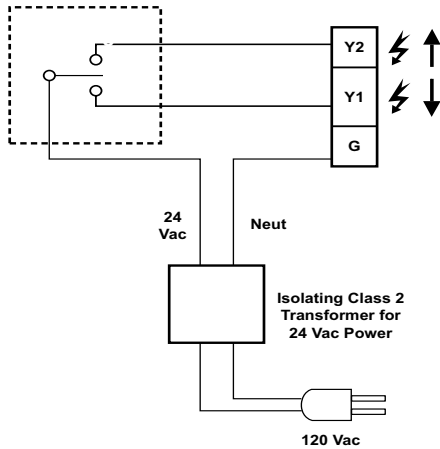

Part No.	Description	Part No.	Fail
	3-position	ENZ2C2	In-Place

Dimensions				
Valve Line Size	Center Line to Top of Actuator	Service Height	Actual Width	Service Width
	H'	H	W'	W
1/2" (15 mm)	4-1/2" (115 mm)	12" (300 mm)	3-1/4" (83 mm)	11" (275 mm)
3/4" (20 mm)	4-1/2" (115 mm)	12" (300 mm)	3-1/4" (83 mm)	11" (275 mm)
1" (25 mm)	4-3/4" (121 mm)	12" (300 mm)	3-1/4" (83 mm)	11" (275 mm)

Specifications

Operating Voltage 24 Vac \pm 20%
 Frequency 50/60 Hz
 Power Consumption 0.8 VA

Function
 Running Time 150 sec.
 Nominal Stroke 7/32" (5.5 mm)
 Nominal Force 45 lb. (200 N)

Agency Approvals UL873
 CSA C22.2 No. 24-93

Ambient Temperature
 Operation 34 to 122°F (1 to 50°C)
 Transport and Storage -13 to +158°F (-25 to +70°C)
 Medium Temperature 34 to 230°F (1 to 110°C)
 Mounting Location NEMA 1 (interior only)

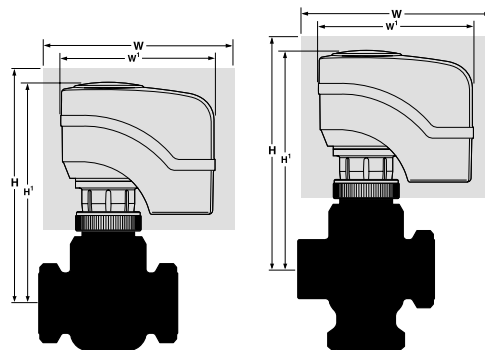

Wiring Diagram

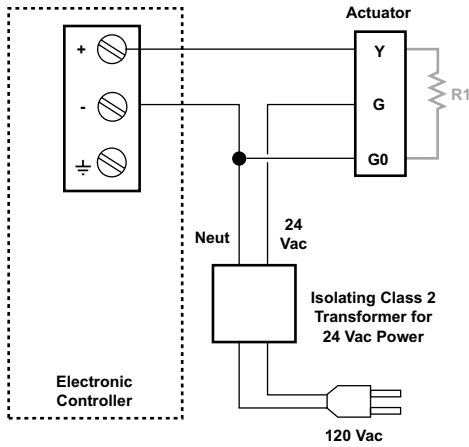

Dimensions						
Valve Line Size	Center Line to Top of Actuator		Service Height		Actual Width of Actuator	Service Width
	H ¹		H		W ¹	W
	NO	NC	NO	NC		
1/2" (15 mm)	5-1/8" (130 mm)		13-1/8" (333 mm)		4-3/4" (121 mm)	12-3/4" (324 mm)
3/4" (20 mm)	5-1/8" (130 mm)		13-1/8" (333 mm)		4-3/4" (121 mm)	12-3/4" (324 mm)
1" (25 mm)	5-3/8" (137 mm)		13-3/8" (340 mm)		4-3/4" (121 mm)	12-3/4" (324 mm)
1-1/4" (32 mm)	6-7/8" (175 mm)	6-3/8" (162 mm)	15" (380 mm)	14-1/2" (368 mm)	4-3/4" (121 mm)	12-3/4" (324 mm)
1-1/2" (40 mm)	6-15/16" (176 mm)	—	15" (380 mm)	—	4-3/4" (121 mm)	12-3/4" (324 mm)
1/2" (15 mm)	5-1/8" (130 mm)		13-1/8" (333 mm)		4-3/4" (121 mm)	12-3/4" (324 mm)
3/4" (20 mm)	5-1/8" (130 mm)		13-1/8" (333 mm)		4-3/4" (121 mm)	12-3/4" (324 mm)
1" (25 mm)	5-3/8" (137 mm)		13-3/8" (333 mm)		4-3/4" (121 mm)	12-3/4" (324 mm)
1-1/4" (32 mm)	6-7/8" (175 mm)	6-3/8" (162 mm)	15" (380 mm)	14-1/2" (370 mm)	4-3/4" (121 mm)	12-3/4" (324 mm)
1-1/2" (40 mm)	6-15/16" (176 mm)	—	15" (380 mm)	—	4-3/4" (121 mm)	12-3/4" (324 mm)

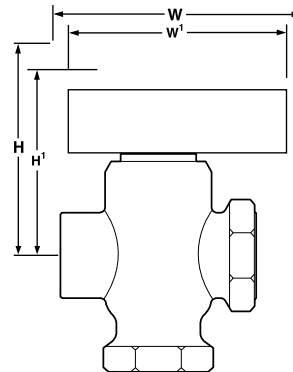

Wiring Diagrams

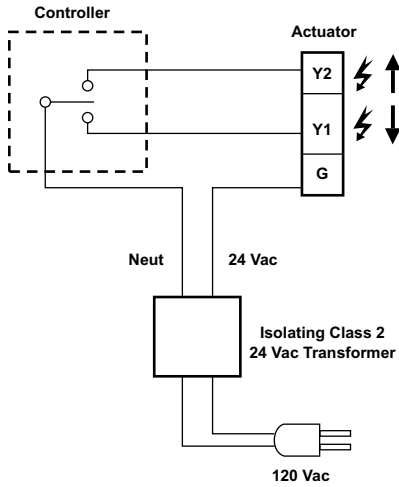

ENZ3C2

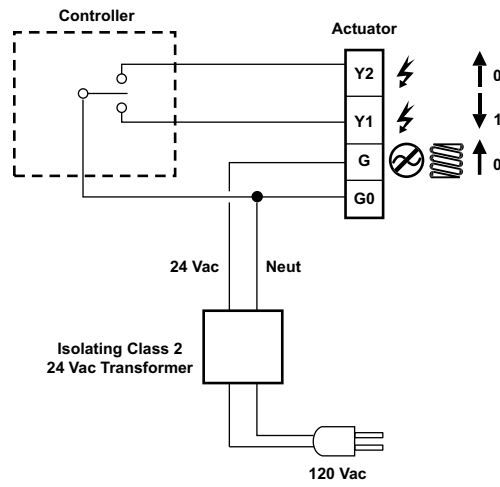

ESZ3C2

Key	
Y2	Retracts actuator shaft
Y1	Extends actuator shaft
G	System Potential
G0	System Neutral

Dimensions						
Valve Line Size	Center Line to Top of Actuator		Service Height		Actual Width of Actuator	Service Width
	H'		H		W'	W
	NO	NC	NO	NC		
1/2" (15 mm)	5-1/8" (130 mm)		13-1/8" (333 mm)		4-3/4" (121 mm)	12-3/4" (324 mm)
3/4" (20 mm)	5-1/8" (130 mm)		13-1/8" (333 mm)		4-3/4" (121 mm)	12-3/4" (324 mm)
1" (25 mm)	5-3/8" (137 mm)		13-3/8" (340 mm)		4-3/4" (121 mm)	12-3/4" (324 mm)
1-1/4" (32 mm)	6-7/8" (175 mm)	6-3/8" (162 mm)	15" (380 mm)	14-1/2" (370 mm)	4-3/4" (121 mm)	12-3/4" (324 mm)
1-1/2" (40 mm)	6-15/16" (176 mm)	—	15" (380 mm)	—	4-3/4" (121 mm)	12-3/4" (324 mm)
1/2" (15 mm)	5-1/8" (130 mm)		13-1/8" (333 mm)		4-3/4" (121 mm)	12-3/4" (324 mm)
3/4" (20 mm)	5-1/8" (130 mm)		13-1/8" (333 mm)		4-3/4" (121 mm)	12-3/4" (324 mm)
1" (25 mm)	5-3/8" (137 mm)		13-3/8" (333 mm)		4-3/4" (121 mm)	12-3/4" (324 mm)
1-1/4" (32 mm)	6-7/8" (175 mm)	6-3/8" (162 mm)	15" (380 mm)	15" (380 mm)	4-3/4" (121 mm)	12-3/4" (324 mm)
1-1/2" (40 mm)	6-15/16" (176 mm)	—	15" (380 mm)	—	4-3/4" (121 mm)	12-3/4" (324 mm)

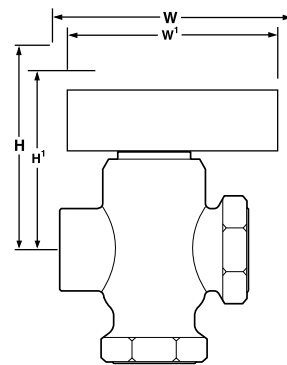



GZ Series Zone Control Valves

Chapter 1 Description

The GZ Series ANSI Class 250 Valve bodies work with any EN/ES Series electronic actuator with a 7/32-inch (5.5 mm) stroke. Typical applications include control of hot or chilled water, glycol solutions up to 50%, or steam up to 15 psi (103 kPa). Compatible actuators deliver a minimum of 45 lbs. (200 N) of force.

Features

- Direct-coupled universal bonnet
- Female NPT connections and brass trim
- ANSI Leakage Class IV (0.01% of Cv)



Chapter 2 Product Numbers

To order a complete valve plus actuator assembly, use the product numbers in the tables. The prefix specifies an actuator and the suffix specifies the valve body.

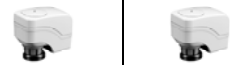
Example: ENZ2B2 / GZ2B-2.5

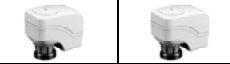
2-Way, Normally Open Valve & Actuator Assemblies with Brass Trim and Female NPT Connections				
Line Size, In. (mm)	Cv (Kvs)	Electro-mechanical, 24V		
		3 pos., fail-in-place	0-10V, fail-in-place	
				
		Actuator Prefix Code		Valve Body
1/2 (15)	0.4 (0.34)	ENZ2C2	ENZ2B2	GZ2A-4
1/2 (15)	0.63 (0.54)	ENZ2C2	ENZ2B2	GZ2A-.63
1/2 (15)	1 (0.85)	ENZ2C2	ENZ2B2	GZ2A-1
1/2 (15)	1.6 (1.37)	ENZ2C2	ENZ2B2	GZ2A-1.6
1/2 (15)	2.5 (2.14)	ENZ2C2	ENZ2B2	GZ2A-2.5
1/2 (15)	4 (3.42)	ENZ2C2	ENZ2B2	GZ2A-4
3/4 (20)	6.3 (5.38)	ENZ2C2	ENZ2B2	GZ2A-6.3
1 (25)	10 (8.55)	ENZ2C2	ENZ2B2	GZ2A-10

2-Way, Normally Closed Valve & Actuator Assemblies with Brass Trim and Female NPT Connections				
Line Size, In. (mm)	Cv (Kvs)	Electro-mechanical, 24V		
		3 pos., fail-in-place	0-10V, fail-in-place	
				
		Actuator Prefix Code		Valve Body
1/2 (15)	0.4 (0.34)	ENZ2C2	ENZ2B2	GZ2B-4
1/2 (15)	0.63 (0.54)	ENZ2C2	ENZ2B2	GZ2B-.63
1/2 (15)	1 (0.85)	ENZ2C2	ENZ2B2	GZ2B-1
1/2 (15)	1.6 (1.37)	ENZ2C2	ENZ2B2	GZ2B-1.6
1/2 (15)	2.5 (2.14)	ENZ2C2	ENZ2B2	GZ2B-2.5
1/2 (15)	4 (3.42)	ENZ2C2	ENZ2B2	GZ2B-4
3/4 (20)	6.3 (5.38)	ENZ2C2	ENZ2B2	GZ2B-.6.3
1 (25)	10 (8.55)	ENZ2C2	ENZ2B2	GZ2B-10

3-Way, Mixing Valve & Actuator Assemblies with Brass Trim and Female NPT Connections				
Line Size, In. (mm)	Cv (Kvs)	Electro-mechanical, 24V		
		3 pos., fail-in-place	0-10V, fail-in-place	
				
		Actuator Prefix Code		Valve Body
1/2 (15)	0.4 (0.34)	ENZ2C2	ENZ2B2	GZ3A-4
1/2 (15)	0.63 (0.54)	ENZ2C2	ENZ2B2	GZ3A-.63
1/2 (15)	1 (0.85)	ENZ2C2	ENZ2B2	GZ3A-1
1/2 (15)	1.6 (1.37)	ENZ2C2	ENZ2B2	GZ3A-1.6
1/2 (15)	2.5 (2.14)	ENZ2C2	ENZ2B2	GZ3A-2.5
1/2 (15)	4 (3.42)	ENZ2C2	ENZ2B2	GZ3A-4
3/4 (20)	6.3 (5.38)	ENZ2C2	ENZ2B2	GZ3A-.6.3
1 (25)	10 (8.55)	ENZ2C2	ENZ2B2	GZ3A-10

Chapter 3 Technical Data

Line Size	1/2 to 1 inch (15 to 25 mm)	Close-off Ratings	According to ANSI/FCI 70-2 See Table 1.
Body	Globe style, UNS CA 844 bronze, ANSI Class 250	Controlled Medium:	
Trim	Brass	Two-way valves	Water, steam, glycol solutions to 50%
Stem	Stainless steel ASTM A582 Type 303, 7/32-inch (5.5-mm) stroke	Three-way valves	Water, glycol solutions to 50%
Seat	Metal-to-metal	Medium Temperature	35 to 250°F (2 to 120°C)
Packing	Ethylene propylene O-ring	Max. Differential Pressure for Modulating Service:	
Mounting	NEMA 1 (interior only)	Liquid (2w and 3w)	25 psi (173 kPa)
Flow characteristics:		Steam (2w only)	15 psi (103 kPa)
Two-way valves	Modified equal percentage	Rangeability	Cv <1 = >50:1, Cv >1 = >100:1
Three-way valves	Linear	Leakage Rate	Class IV (0.01% of Cv)

Table 1. Close-Off Ratings.

Action	Line Size Inches (mm)	Flow Rate, Cv (Kvs)	Close-Off Ratings psi (kPa)	Action	Line Size Inches (mm)	Flow Rate, Cv (Kvs)	Close-Off Ratings psi (kPa)
			Electronic Actuator ENZ2/ESZ2				Electronic Actuator ENZ2/ESZ2
NC	1/2 (15)	0.4 to 1.6 (0.34 to 1.37)	70 (483)	3-Way Mixing, upper	1/2 (15)	0.4 to 1.6 (0.34 to 1.37)	70 (483)
	1/2 (15)	2.5 to 4 (2.15 to 3.44)	40 (276)		1/2 (15)	2.5 to 4 (2.15 to 3.44)	40 (276)
	3/4 (20)	6.3 to 10 (5.43 to 8.6)	30 (207)		3/4 (20) and 1 (25)	6.3 to 10 (5.43 to 8.6)	30 (207)
NO	1/2 (15)	0.4 to 1.6 (0.34 to 1.37)	60 (412)	3-Way Mixing, lower	1/2 (15)	0.4 to 1.6 (0.34 to 1.37)	25 (172)
	1/2 (15)	2.5 to 4 (2.15 to 3.44)	35 (241)		1/2 (15)	2.5 to 4 (2.15)	15 (103)
	3/4 (20)	6.3 to 10 (5.43 to 8.6)	30 (207)		3/4 (20) and 1 (25)	6.3 to 10 (5.43 to 8.6))	10 (69)

Table 2. Valve Dimensions.

2-Way Valve

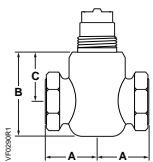

3-Way Valve

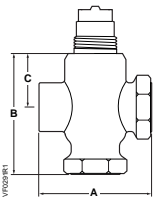

Size In. (mm)	A	B	C	Weight lbs. (kg)
1/2 (15)	1-3/8 (35)	2-1/4 (57)	1-5/16 (33)	1.3 (0.6)
3/4 (20)	1-5/8 (41)	2-3/8 (59)	1-5/16 (33)	1.8 (0.8)
1 (25)	1-15/16 (49)	2-3/4 (69)	1-9/16 (39)	2.6 (1.2)
1/2 (15)	2-3/4 (69)	2-1/4 (74)	1-5/16 (33)	1.5 (0.7)
3/4 (20)	3-1/4 (83)	3-9/16 (90)	1-5/16 (33)	2.3 (1.05)
1 (25)	3-7/8 (98)	3-9/16 (99)	1-9/16 (39)	3.3 (1.5)

Chapter 4 Typical Specifications

Automatic control valves shall have NPT threaded type fittings, 1/2 through 1 inch (15 through 25 mm) sizes, and shall be ANSI rated to withstand the pressures and temperatures encountered. Valves shall have metal-to-metal seats, stainless steel stems, and Ethylene propylene O-ring packing. Valve shall be ANSI Leakage Class IV (0.01% of Cv). Valves shall have a 50:1 rangeability (Cv <1) or better.

All two-way valves shall be provided with equal-percentage contoured throttling plugs. All three-way valves shall be provided with throttling plugs such that the total flow through the valve remains constant (linear) regardless of the valve position.

For complete technical details on valves with stainless steel trim, or union female, angle female, or union male end connections, see *GT Series Terminal Unit Valves Technical Instructions*.

Information in this publication is based on current specifications. The company reserves the right to make changes in specifications and models as design improvements are introduced.



GT Series Terminal Unit 2-Way Valves

Description

The ANSI Class 250 GT Series 2-Way Valve bodies work with any EN/ES1 AND EN/ES3 Series pneumatic or electronic actuator with a 7/32-inch (5.5-mm) stroke. They are suitable for normally open or normally closed control. Typical applications include control of hot or chilled water, glycol solutions up to 50%, or steam up to 15 psi (103 kPa). Compatible actuators deliver a minimum of 67 lbs. (300 N) of force.







Features

- Direct-coupled universal bonnet
- Female NPT end connections and brass trim
- ANSI Leakage Class IV (0.01% of Cv)

Product Numbers

To order a complete valve plus actuator assembly, use the product numbers in the tables. The prefix specifies an actuator and the suffix specifies the valve body.

**Examples: ENZ1B2 / GT2B-2.5 or
PS2A / GT2B-1.6**

2-Way Valve & Actuator Assemblies with Brass Trim and Female NPT Connections									
 Valve Body	Line Size, In. (mm)	Cv (Kvs)	2-Inch Pneumatic Actuators, fail-safe 	Electro-mechanical, 24V					
				3 pos., fail-in-place	3 pos., fail-safe	0-10V, fail-in-place	0-10V, fail-safe,	3 pos., fail-safe	
				    					
Actuator Prefix Code									
Normally Closed	GT2B-.4	1/2 (15)	0.4 (0.34)	PS2A	ENZ3C2	ESZ3C2	ENZ1B2	ESZ1B2	ESZ1C2
	GT2B-.63	1/2 (15)	0.63 (0.54)	PS2A	ENZ3C2	ESZ3C2	ENZ1B2	ESZ1B2	ESZ1C2
	GT2B-1	1/2 (15)	1 (0.85)	PS2A	ENZ3C2	ESZ3C2	ENZ1B2	ESZ1B2	ESZ1C2
	GT2B-1.6	1/2 (15)	1.6 (1.37)	PS2A	ENZ3C2	ESZ3C2	ENZ1B2	ESZ1B2	ESZ1C2
	GT2B-2.5	1/2 (15)	2.5 (2.14)	PS2A	ENZ3C2	ESZ3C2	ENZ1B2	ESZ1B2	ESZ1C2
	GT2B-4	1/2 (15)	4 (3.42)	PS2A	ENZ3C2	ESZ3C2	ENZ1B2	ESZ1B2	ESZ1C2
	GT2B-6.3	3/4 (20)	6.3 (5.38)	PS2A	ENZ3C2	ESZ3C2	ENZ1B2	ESZ1B2	ESZ1C2
	GT2B-10	1 (25)	10 (8.55)	PS2A	ENZ3C2	ESZ3C2	ENZ1B1	ESZ1B2	ESZ1C2
Normally Open	GT2A-.4	1/2 (15)	0.4 (0.34)	PS2A	ENZ3C2	ESZ3C2	ENZ1B2	ESZ1B2	ESZ1C2
	GT2A-.63	1/2 (15)	0.63 (0.54)	PS2A	ENZ3C2	ESZ3C2	ENZ1B2	ESZ1B2	ESZ1C2
	GT2A-1	1/2 (15)	1 (0.85)	PS2A	ENZ3C2	ESZ3C2	ENZ1B2	ESZ1B2	ESZ1C2
	GT2A-1.6	1/2 (15)	1.6 (1.37)	PS2A	ENZ3C2	ESZ3C2	ENZ1B2	ESZ1B2	ESZ1C2
	GT2A-2.5	1/2 (15)	2.5 (2.14)	PS2A	ENZ3C2	ESZ3C2	ENZ1B2	ESZ1B2	ESZ1C2
	GT2A-4	1/2 (15)	4 (3.42)	PS2A	ENZ3C2	ESZ3C2	ENZ1B2	ESZ1B2	ESZ1C2
	GT2A-6.3	3/4 (20)	6.3 (5.38)	PS2A	ENZ3C2	ESZ3C2	ENZ1B2	ESZ1B2	ESZ1C2
	GT2A-10	1 (25)	10 (8.5)	PS2A	ENZ3C2	ESZ3C2	ENZ1B2	ESZ1B2	ESZ1C2

Technical Data

Line Size	1/2 to 1 inch (15 to 25 mm)	Controlled Medium	Water, steam, glycol solutions to 50%
Body	Globe style, UNS CA 844 bronze, ANSI Class 250	Medium Temperature	35 to 250°F (2 to 120°C)
Trim	Brass	Max. Differential Pressure for Modulating Service:	
Stem	Stainless steel ASTM A582 Type 303, 7/32-inch (5.5-mm) stroke	Liquid	25 psi (173 kPa)
Seat	Metal-to-metal	Steam	15 psi (103 kPa)
Packing	Ethylene propylene O-ring	Rangeability	Cv <1 = >50:1, Cv >1 = >100:1
Close-off Ratings	According to ANSI/FCI 70-2 See Table 1.	Leakage Rate	Class IV (0.01% of Cv)
		Flow Characteristics	Modified equal percentage
		Mounting	NEMA 1 (interior only)

Table 1. Close-Off Ratings in psi (kPa).

Action	Line Size Inches (mm)	Flow Rate, Cv (Kvs)	Close-Off Ratings				
			Electronic Actuator		Pneumatic Actuator – PS2A @ 20 psi (138 kPa)		
			EN/ESZ1	EN/ESZ3	3-8 psi (69-103 kPa)	8-13 psi (21-55 kPa)	10-15 psi (55-90 kPa)
NC	1/2 (15)	0.4 to 1.6 (0.34 to 1.37)	95 (655)	95 (655)	40 (276)	95 (655)	95 (655)
	1/2 (15)	2.5 to 4 (2.15 to 3.44)	50 (345)	50 (345)	28 (193)	50 (345)	50 (345)
	3/4 (20) & 1 (25)	6.3 to 10 (5.43 to 8.6)	40 (276)	40 (276)	18 (124)	40 (276)	40 (276)
NO	1/2 (15)	0.4 to 1.6 (0.34 to 1.37)	160 (1103)	120 (828)	95 (655)	45 (310)	20 (138)
	1/2 (15)	2.5 to 4 (2.15 to 3.44)	85 (586)	65 (448)	45 (310)	25 (172)	15 (103)
	3/4 (20) & 1 (25)	6.3 to 10 (5.43 to 8.6)	70 (482)	55 (379)	35 (241)	10 (69)	---

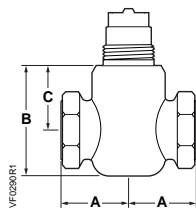

Female NPT x Female NPT

Valve Size In. (mm)	A	B		C		Weight lbs. (kg)
		NO	NC	NO	NC	
1/2 (15)	1-3/8 (35)	2-1/4 (57)		1-5/16 (33)		1.3 (0.6)
3/4 (20)	1-5/8 (41)	2-3/8 (59)		1-5/16 (33)		1.8 (0.8)
1 (25)	1-15/16 (49)	2-3/4 (69)		1-9/16 (39)		2.6 (1.2)

Figure 1. Two-way Valve Dimensions in Inches (mm).

Typical Specifications

Automatic control valves shall have NPT threaded type fittings, 1/2 through 1 inch (15 through 25mm) sizes, and shall be ANSI rated to withstand the pressures and temperatures encountered.

Valves shall have metal-to-metal seats, stainless steel stems, and Ethylene propylene O-ring packing.

Valve shall be ANSI Leakage Class IV (0.01% of Cv). Valves shall have a 50:1 rangeability (Cv <1) or better.

All two-way valves shall be provided with equal-percentage contoured throttling plugs.

For complete technical details on valves with stainless steel trim, or union female, angle female, or union male end connections, see *GT Series Terminal Unit Two-way Valves Technical Instructions*.

Information in this publication is based on current specifications. The company reserves the right to make changes in specifications and models as design improvements are introduced.



GT Series Terminal Unit 3-Way Valves

Description

The GT Series ANSI Class 250 3-Way Valve bodies work with any EN/ES1 and EN/ES3 Series Electronic or PS2A Pneumatic actuator with a 7/32-inch (5.5 mm) stroke. Typical applications include mixing of hot or chilled water and the control of glycol solutions up to 50%. Compatible actuators deliver a minimum of 67 lbs. (300 N) of force.









Product Numbers

To order a complete valve plus actuator assembly, use the product numbers in the tables. The prefix specifies an actuator and the suffix specifies the valve body.

Examples: ENZ1B2 / GT3A-2.5 or PS2A / GT3A-1.6

Features

- Direct-coupled universal bonnet
- Female NPT end connections and brass trim
- ANSI Leakage Class IV (0.01% of Cv)

3-Way, Mixing Valve & Actuator Assemblies with Brass Trim										
 Valve Body ¹	Line Size, In. (mm)	Cv (Kvs)	2-Inch Pneumatic Actuators, fail-safe 	Electro-mechanical, 24V						
				3 pos., fail-in-place	3 pos., fail-safe	0-10V, fail-in-place	0-10V, fail-safe	0-10V, fail-in-place	0-10V, fail-safe,	3 pos., fail-safe
										
Actuator Prefix Code										
GT3A-.4	1/2 (15)	0.4 (0.34)	PS2*	ENZ3C2	ESZ3C2	ENZ3B2	ESZ3B2	ENZ1B2	ESZ1B2	ESZ1C2
GT3A-.63	1/2 (15)	0.63 (0.54)	PS2*	ENZ3C2	ESZ3C2	ENZ3B2	ESZ3B2	ENZ1B2	ESZ1B2	ESZ1C2
GT3A-1	1/2 (15)	1 (0.85)	PS2*	ENZ3C2	ESZ3C2	ENZ3B2	ESZ3B2	ENZ1B2	ESZ1B2	ESZ1C2
GT3A-1.6	1/2 (15)	1.6 (1.37)	PS2*	ENZ3C2	ESZ3C2	ENZ3B2	ESZ3B2	ENZ1B2	ESZ1B2	ESZ1C2
GT3A-2.5	1/2 (15)	2.5 (2.14)	PS2*	ENZ3C2	ESZ3C2	ENZ3B2	ESZ3B2	ENZ1B2	ESZ1B2	ESZ1C2
GT3A-4	1/2 (15)	4 (3.42)	PS2*	ENZ3C2	ESZ3C2	ENZ3B2	ESZ3B2	ENZ1B2	ESZ1B2	ESZ1C2
GT3A-6.3	3/4 (20)	6.3 (5.38)	PS2*	ENZ3C2	ESZ3C2	ENZ3B2	ESZ3B2	ENZ1B2	ESZ1B2	ESZ1C2
GT3A-10	1 (25)	10 (8.55)	PS2*	ENZ3C2	ESZ3C2	ENZ3B2	ESZ3B2	ENZ1B2	ESZ1B2	ESZ1C2

¹ All valves are positioned fail bottom to right normally open.

* Control signal range: A = 3 - 8 PSI, B = 8 - 13 PSI, C = 10 - 15 PSI.

Technical Data

Line Size	1/2 to 1 inch (15 to 25 mm)	Controlled Medium	Water, steam, glycol solutions to 50%
Body	Globe style, UNS CA 844 bronze, ANSI Class 250	Medium Temperature	35 to 250°F (2 to 120°C)
Trim	Brass	Max. Differential Pressure for Modulating Service	25 psi (173 kPa)
Stem	Stainless steel ASTM A582 Type 303, 7/32-inch (5.5-mm) stroke	Rangeability	Cv <1 = >50:1, Cv >1 = >100:1
Seat	Metal-to-metal	Leakage Rate	Class IV (0.01% of Cv)
Packing	Ethylene propylene O-ring	Flow Characteristics	Linear
Spring Range	8 to 13 psi (55 to 90 kPa)	Mounting	NEMA 1 (interior only)
Close-off Ratings	According to ANSI/FCI 70-2 See Table 1.		

Table 1. Close-Off Ratings in psi (kPa).

Action	Line Size Inches (mm)	Flow Rate, Cv (Kvs)	Close-Off Ratings				
			Electronic Actuator		Pneumatic Actuator – PS2 @ 20 psi (138 kPa)		
			EN/ES1	EN/ES3	PS2A 3-8 psi (69-103 kPa)	PS2B 8-13 psi (21-55 kPa)	PS2C 10-15 psi (55-90 kPa)
3-way, lower Normally Open	1/2 (15)	0.4 to 1.6 (0.34 to 1.37)	160 (1103)	95 (828)	95 (655)	45 (310)	20 (138)
	1/2 (15)	2.5 to 4 (2.15 to 3.44)	85 (586)	55 (448)	45 (310)	25 (172)	15 (103)
	3/4 (20) and 1 (25)	6.3 to 10 (5.43 to 8.6)	70 (482)	40 (379)	35 (241)	10 (69)	---
3-way, upper Normally Closed	1/2 (15)	0.4 to 1.6 (0.34 to 1.37)	95 (655)	95 (655)	40 (276)	95 (655)	95 (655)
	1/2 (15)	2.5 to 4 (2.15 to 3.44)	50 (345)	50 (345)	28 (193)	50 (345)	50 (345)
	3/4 (20) and 1 (25)	6.3 to 10 (5.43 to 8.6)	40 (276)	40 (276)	18 (124)	40 (276)	40 (276)

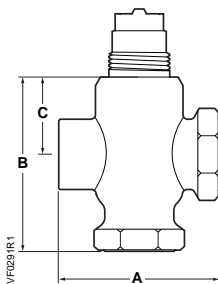

Valve Size In. (mm)	A	B	C	Weight lbs. (kg)
1/2 (15)	2-3/4 (70)	2-15/16 (74)	1-5/16 (33)	1.5 (0.7)
3/4 (20)	3-1/4 (83)	3-9/16 (90)	1-5/16 (33)	2.3 (1.1)
1 (25)	3-7/8 (98)	3-15/16 (99)	1-9/16 (39)	3.3 (1.5)

Figure 1. 3-way Valve Dimensions in Inches (mm).

Typical Specifications

Automatic control valves shall have NPT threaded type fittings, 1/2 through 1 inch (15 through 25 mm) sizes, and shall be ANSI rated to withstand the pressures and temperatures encountered.

Valves shall have metal-to-metal seats, stainless steel stems, and Ethylene propylene O-ring packing.

Valve shall be ANSI Leakage Class IV (0.01% of Cv). Valves shall have a 50:1 rangeability (Cv <1) or better.

All three-way valves shall be provided with throttling plugs such that the total flow through the valve remains constant (linear) regardless of the valve position.

For complete technical details on valves with stainless steel trim, see *GT Series Terminal Unit Three-way Valves Technical Instructions*.

Information in this publication is based on current specifications. The company reserves the right to make changes in specifications and models as design improvements are introduced.



**Dodge Engineering
& Controls, Inc.**

***Zone Control Valves
and
Terminal Unit Valves***

**A NEW ADDITION TO OUR
PRODUCT LINE FOR A MORE
COMPLETE SOLUTION FOR YOU!**

Toll-free (877) 334-2875



Zone Control and Terminal Unit Valves Type A

Close-Off Pressures	
– Normally Closed	Z-1
– Normally Open	Z-2
ENZ2B2 Valve Actuator	Z-3
ENZ2C2 Valve Actuator	Z-4
ENZ3B2 and ESZ3B2 Electronic Valve Actuator	Z-5
ENZ3C2 and ESZ3C2 Electronic Valve Actuator	Z-7
GZ Series Zone Control Valves	Z-9
GT Series Terminal Unit 2-Way Valves	Z-11
GT Series Terminal Unit 3-Way Valves	Z-13
Pricing	PR-7 & 8